

Installation & Instruction Manual



Opera-H



Opera-J

Note: Read this manual carefully before installing the operator and place this installation manual in an accessible place near the operator. For future reference record:

Model # _____

Date _____

Wiring Diagram # _____

Model # _____

Project No. _____

Project Name _____

Door No. # _____



IMPORTANT SAFETY INSTRUCTIONS**WARNING**

TO REDUCE THE RISK OF SEVERE INJURY OR DEATH, READ AND FOLLOW ALL INSTRUCTIONS.

1. Never allow children to operate or play with or near door.
2. Check to see that the operator is correct for the type, size of door and frequency of use per the operator specifications.
3. If the door system is near a residential area, or pedestrian traffic is expected near the door system, additional equipment such as electric reversing edges, photocells, or similar devices must be installed as part of the system to prevent entrapment.
4. Reversing devices appropriate to the application must be installed as part of the system.
5. Outdoor or easily accessible controls must be of the security type to prevent unauthorized use of the system.
6. Place controls far enough from the door so that a user cannot touch the door when operating the controls.
7. Controls should be placed so the user has full view of the door when operating.
8. Always keep moving door in sight and away from people or vehicles until it is completely opened or closed. **NO ONE SHOULD CROSS THE PATH OF THE MOVING DOOR.**
9. If a person is trapped under the door, push the "OPEN" control button.
10. Do not overtighten a clutch to compensate for a damaged door.
11. Test door and service monthly. After adjusting the limit travel, retest the door opener. Failure to adjust the door may cause death or injury.
12. **KEEP DOORS PROPERLY BALANCED.** See door owner's manual. An improperly balanced door could cause severe injury. Have a qualified service person make repairs to cables, spring assemblies and other hardware.
13. If possible, use the emergency release only when the door is closed. Use caution when using this release with the door open. Weak or broken springs may cause the door to fall rapidly, causing injury or death.
14. You are responsible for assuring that the owner of the door system understands its basic operation and safety. In particular, be sure the owner/end-user understands the location and operation of the manual disconnect.
15. Point out to the owner/end-user of the door system that children or pets should not be allowed to play on or near the door or any part of the system, and that the safety instructions supplied with this operator are the responsibility of the owner/end-user.
16. Leave the installation and maintenance manual for this operator as well as any additional information supplied with this operator or other components of the door system with the owner/end-user.
17. If you have any question about the safety of the door operating system, do not install the operator, contact us.

**WARNING**

DO NOT CONNECT POWER SUPPLY WHILE INSTALLING, SERVICING OR ADJUSTING THE ELECTRIC OPERATOR

**WARNING**

NOT APPLICABLE FOR RESIDENTIAL USE. ONLY FOR INDUSTRIAL AND COMMERCIAL APPLICATIONS

TABLE OF CONTENTS

	Page
GENERAL PARTS & SPECIFICATIONS.....	4
WEIGHT AND DIMENSIONS.....	4
PRODUCT APPLICATION.....	5
DELIVERY OF OPERATOR.....	5
HARDWARE.....	5
INSTALLATION.....	6-10
ADJUSTMENT OF LIMIT SWITCHES.....	11
SUGGESTED WIRE SIZE.....	11
MANUAL OPERATION OF Opera-H & Opera-J.....	12
SCHEDULE MAINTENANCE.....	14
Opera-H EXPLODED VIEW.....	15
Opera-J EXPLODED VIEW.....	16
ELECTRONIC CONTROL BOARD.....	17
• Power, Control and Accessory Wiring.....	18
• Program Setting.....	22
• Mode Setting.....	23
• Door Lock Sensor & Friction Clutch.....	24
• Limit Switches.....	25
• Troubleshooting of ECB.....	25-26
• Single phase Wiring Diagram.....	27
• 3-phase Wiring Diagram.....	28
RED & GREEN WARNING LIGHTS.....	29
• Warning lights sequence.....	30
• Programming of warning lights sequence.....	30
• Connection of Red & Green lights.....	30
HARD WIRING CONTROL CIRCUIT.....	31
• Wiring of an opera.....	32-33
• Accessory Wiring.....	34
• Limit Switches.....	36
• Troubleshooting of a hard wiring circuit.....	37-39
• Single phase Wiring Diagram.....	40
• 3-phase Wiring Diagram.....	41
WARRANTY POLICY.....	42
NOTES.....	43

SPECIFICATIONS

GENERAL

SUPPLY VOLTAGE.....	115, 230 VAC single phase, 208, 460, 575VAC three phase
CONTROL VOLTAGE.....	24VAC class II transformer 2 amp fuse type AC
MOTOR.....	Continuous duty 1/3, 1/2, 3/4, 1 Horsepower
OPERATOR OUTPUT SPEED.....	41 RPM
NET WEIGHT (Operator only).....	58 Lbs (27 Kg) for 1/2HP 115V Opera-H model
STANDARD WIRING TYPE.....	C2-momentary contact to open and stop and constant pressure to close

DIMENSIONS (Opera-H)

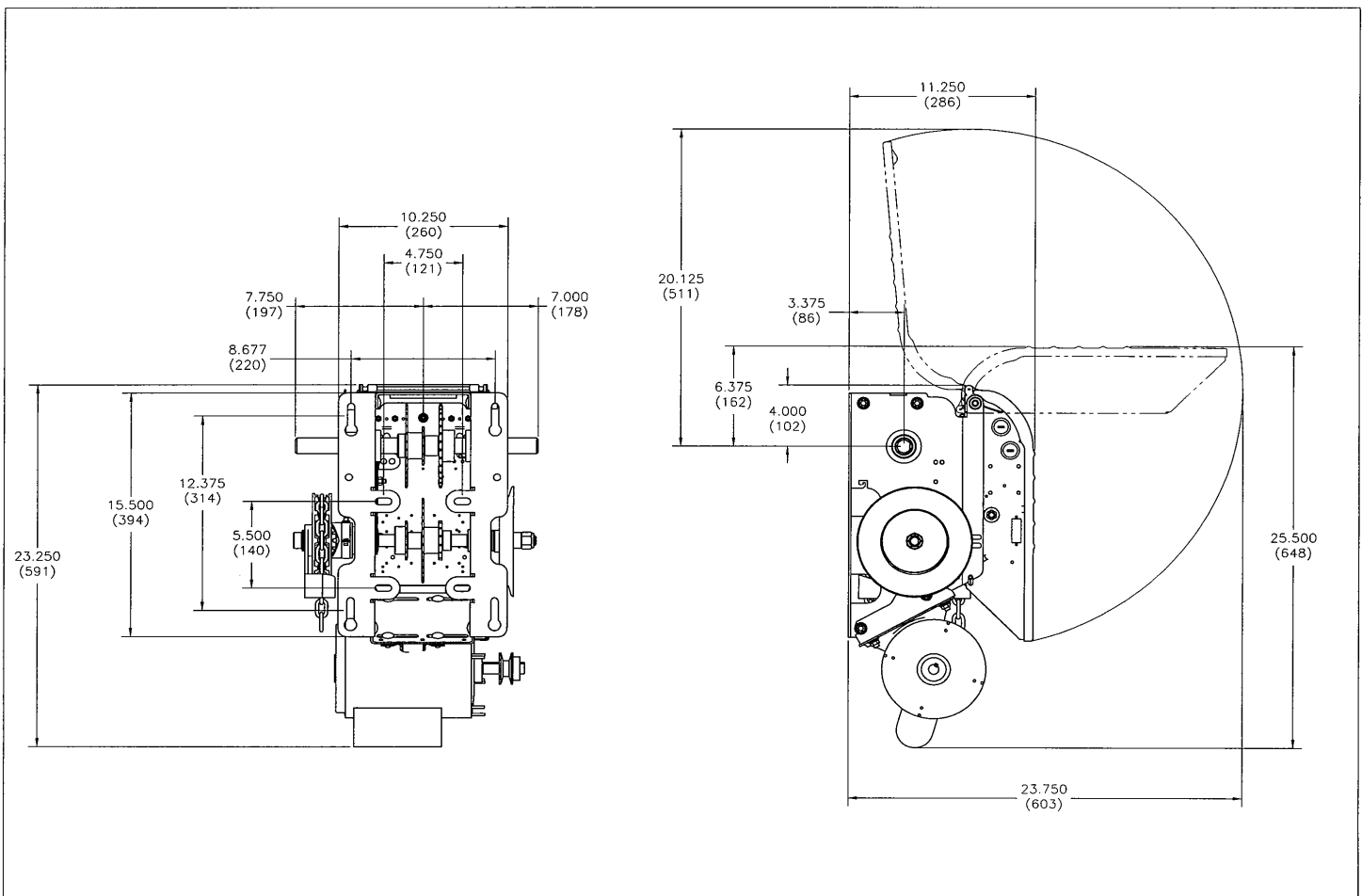

*** NOTE: Opera-H/J with NEMA7/9 modifications are not UL certified

OPERA: HEAVY DUTY JACKSHAFT OPERATOR

IMPORTANT: UPON COMPLETION OF OPERATOR INSTALLATION THIS MANUAL MUST BE GIVEN TO THE END-USER.

1. PRODUCT APPLICATION

The model OPERA heavy-duty jackshaft operator is designed for use on commercial or industrial doors of all types provided that the door has a shaft as basic driving element (doors with high lift, vertical lift, rolling doors and grilles). All OPERA door operators are designed and constructed in accordance with UL325 Standard, and certified by CSA Laboratories.

2. DELIVERY OF OPERATOR

Upon delivery of your heavy-duty jackshaft operator OPERA, inspect the unit immediately for shipping damage. Verify that you have received all the hardware parts mentioned in TABLE 1 and shown in *Figure 1*. Other items may be present, such as radio controls or other types of optional equipment, if ordered. If any item is missing or if there is evidence of damage, call the transport company first.

* Check to make sure that the available power supply to be connected to the operator is of the same voltage, frequency, phase and amperage as indicated on the nameplate of the operator.

3. HARDWARE

TABLE 1 STANDARD PARTS LIST FOR OPERA JACKSHAFT OPERATOR

PART #	QTY	DESCRIPTION
1	1	Pocket wheel hand chain (2X door shaft less 4 ft. (1.2m))for Opera-H or disconnect chain (14') for Opera-J
2	1	3-button open/close/stop push-button station
3	1	#50 connecting link
4	1	#50 roller chain x 4'(1.2m) or x 5' when sprocket is 42 teeth or more.
5	1	** Sprocket 50B x \varnothing " c/w set screws for door shaft
6	1	Sprocket 50B12 x \varnothing 1,0 " c/w set screws for OPERA™ output shaft
7	1	Square shaft key 1/4" x 1-1/2" L for OPERA™ output shaft
8	1	Chain keeper for Opera-J only
9	4	3/8" x 1-1/4" bolts
10	4	3/8" washers
11	4	3/8" lock washers
12	4	3/8" nuts
13	1	Chain keeper for Opera-H only

** See SPECIFICATIONS, DOOR SPEED AND AVAILABLE DOOR ADJUSTMENT

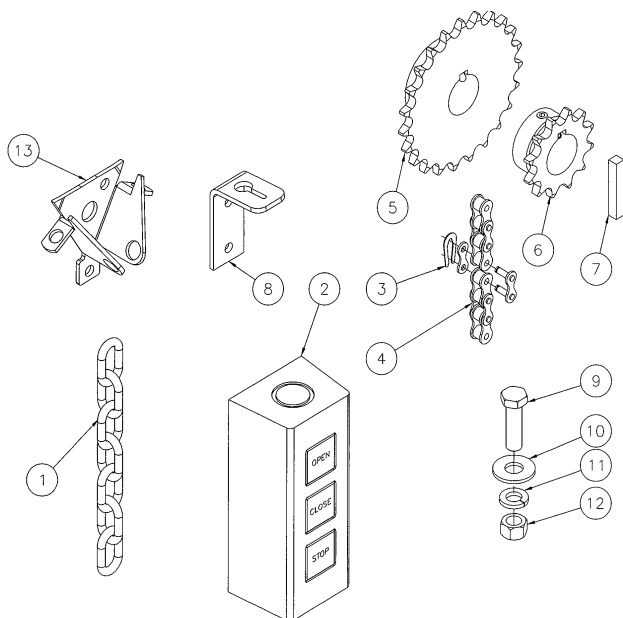

Ensure that the Warning tag supplied with the operator is properly fixed on the door and it is visible while the door is moving

Figure 1 Hardware and Danger Warning Tag

4. INSTALLATION

All heavy-duty OPERA jackshaft operators are tested and adjusted at the factory. When installing your unit, please note that the cams are resting in the center of the cam-shaft.

The OPERA operator has a dual output shaft and may be mounted on either the left or right hand side of a sectional door (see Figure 2 and Figure 3). Place sprocket on either the right or the left end of the output shaft according to the desired handing.

The **Opera-H** comes with a chain hoist located on the right of the operator. If handing requires the chain hoist to be on the left (rolling doors, left operator hood mounting for ex.), it must be requested at the time of ordering. Do not attempt to change handing of the chain yourself.

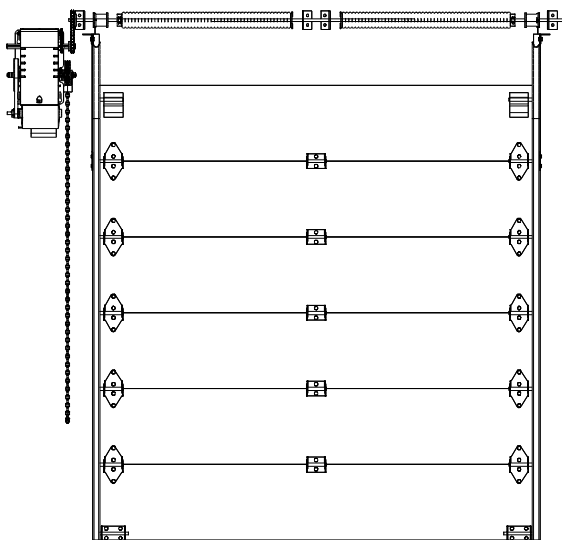

Figure 2 Left side mount

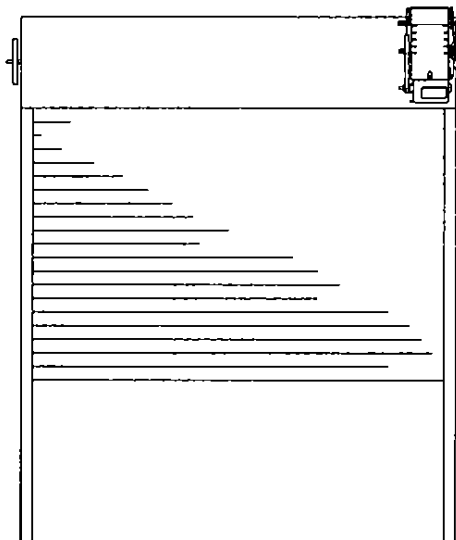

Figure 3 Right side hood mount

4.1 IMPORTANT INSTALLATION INSTRUCTIONS



WARNING

TO REDUCE THE RISK OF SEVERE INJURY OR DEATH, READ AND FOLLOW ALL INSTALLATION INSTRUCTIONS.

1. Installation of this door operator must be done by a qualified installer.
2. Insure that the door is properly installed and works freely in both directions. Do not install the operator until all door problems have been corrected. If necessary, oil all moving parts (chains, rollers, guides, etc.).
3. Remove all old accessories (locks, bolts, etc.) before installing door operator.
4. Do not connect the operator to a source of power until instructed to do so.
5. Locate control push-button station within sight of the door, at a minimum height of 5 ft. (1.5 m) so small children cannot reach it, and away from all moving parts of the door.

4.2 INSTALLATION OF OPERA OPERATOR

IMPORTANT NOTE: THIS OPERATOR MUST BE INSTALLED A MINIMUM OF 8 FT. (2.4 m) ABOVE FLOOR

The OPERA has two sets of mounting holes: outside the frame for wall mounting and inside the frame for hood mounting. To access inside mounting holes, lift control enclosure as shown in Figure 4.

- Pull on the holding rod,

- Lift completely and push up on the holding arm to lock it into place.

To unlock, simply lift control enclosure, pull arm and lower enclosure. Snap enclosure so as to have the rod engaging on both sides of the frame.

Verify the correct position of the lever on Disconnect Switch.

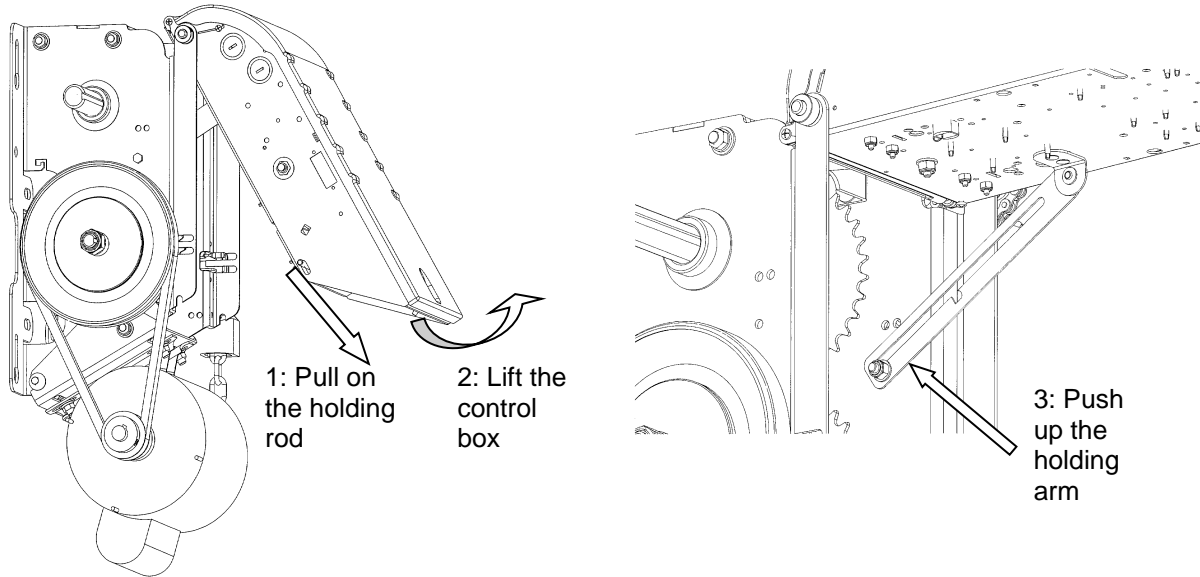

Figure 4 Access to inside of frame

To open the control box cover, loosen the screw at the base of the cover. If the cover cannot be fully opened, the retaining cam may be used to hold the cover in other positions.

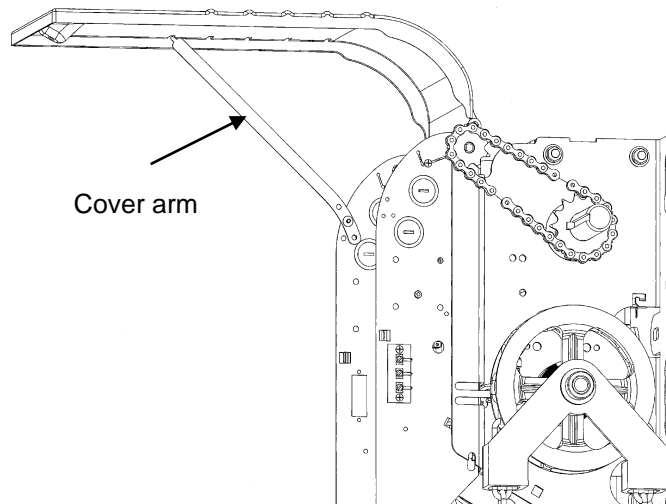

Figure 5 Control box cover opening

After installation, verify that there is no obstacle in the way when opening the control box cover. If so, it is possible to remove the cover by unscrewing it from the box before putting the operator on the wall or hood (see Figure 6).

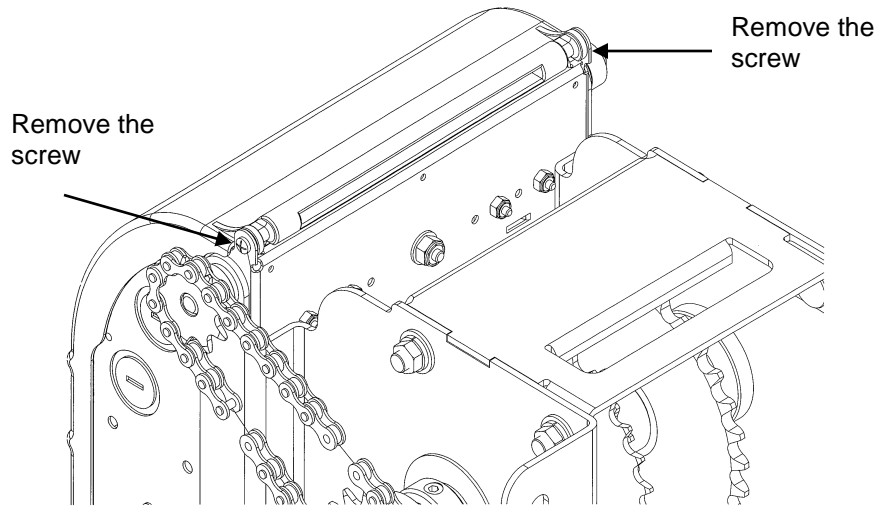

Figure 6 Unscrewing control box

Locate the four mounting holes. The optimum distance between the door shaft and operator drive shaft is between 12" and 15". Mount the OPERA unit by fastening it to the wall, bench or hood with 3/8" or 1/2" thru-bolts or if the wall is of such construction so as to prohibit use of thru-bolts, lag bolts and shields of sufficient size may be used. Do not tighten.

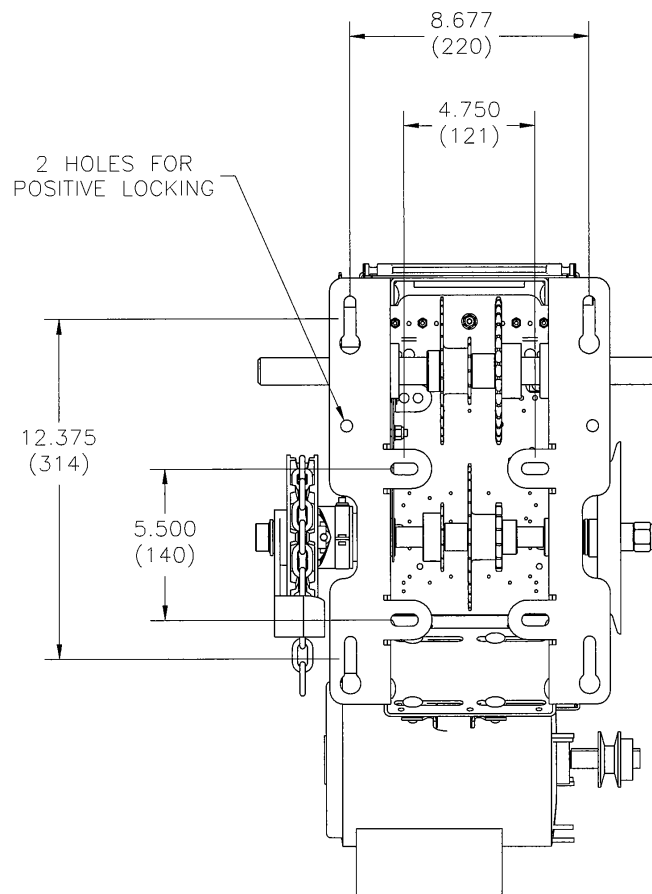

Figure 7 Mounting dimensions for wall or hood

Once the operator is fixed by using the 4 standard mounting holes already provided on the frame, the Positive Locking Holes ($\text{Ø } 7/16''$) can also be used to prevent the operator from moving during the operation (due to vibrations or if any fixing bolt becomes loose). Using these holes will also keep the drive chain alignment straight and will avoid abusive wear to the sprockets.



WARNING
MAKE CERTAIN THAT OPERATOR IS PERFECTLY ALIGNED WITH DOOR SHAFT OTHERWISE
DAMAGE CAN OCCUR

1. Place the driven sprocket on the door shaft loosely and align it with the drive sprocket of the operator.

NOTE: If a chain spreader has been ordered along with your operator, see Figure 8 and Figure 9 below for installation.

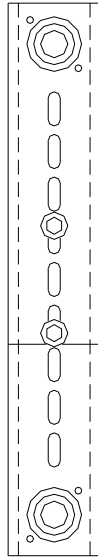

Figure 8 Chain spreader

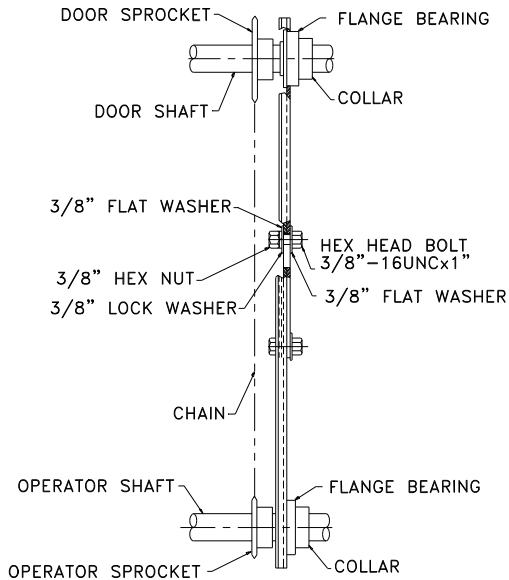

Figure 9 Chain spreader mounted on door and operator shafts

2. Lock the drive and driven sprockets in place by inserting the keys and tightening their respective set screws.
3. Connect the sprockets with the drive chain, shorten to a suitable length and join together with the chain link provided in the hardware bag. To shorten the chain, punch out the pin that will leave an inside link nearest to the desired length. Connect the chain around the sprockets using the chain link (Figure 10).

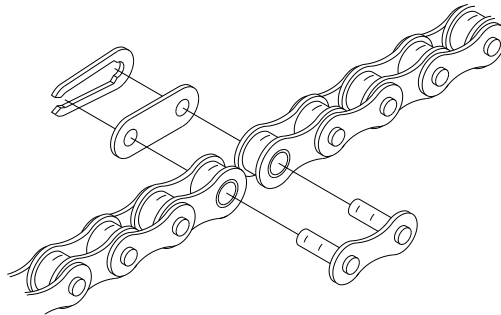

Figure 10 Chain link

4. Slide the operator to tighten the drive chain and then firmly tighten the mounting bolts. Check the tension on the chain and the set screws on the sprockets (there should be no more than 1/4" slack when chain is depressed between sprockets)
5. **Opera-H:** run hand chain through the pocket wheel and through the chain guide outside the frame (Figure 11A), allow both ends to hang down toward the ground and cut hand chain, if necessary, so that both ends are approximately 2 feet (0.6 m) from floor. Connect both ends of hand chain.
6. **Opera-J:** link the disconnect chain at the key ring or hook located at the extremity of the disconnect pull cable (Figure 11B) Place the Opera-J chain keeper so that, when pulled and engaged, the disconnect chain keeps the machine "disconnected" and in the manual position.

**WARNING**

BEFORE PULLING HAND CHAIN THROUGH POCKET WHEEL OR LIFTING THE DOOR DIRECTLY BY HAND, PULL CAM PLATE AND SPIN CAM NUTS TO CENTER OF LIMIT SHAFT SO AS TO BE SURE THE CAMS ARE NOT BEING MECHANICALLY DRIVEN THROUGH THEIR NORMAL LIMIT SWITCH END POSITIONS.

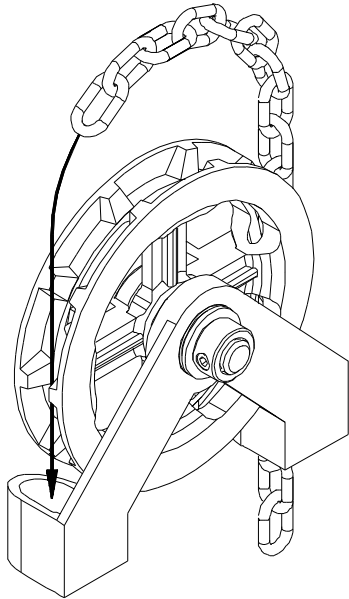

Figure 11 A Installing hand chain on Opera-H

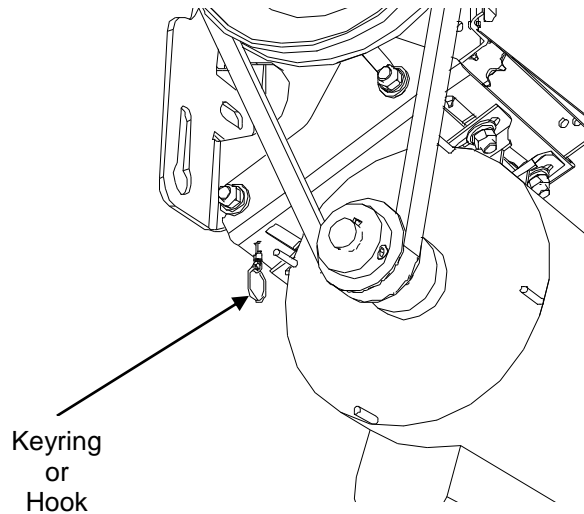

Figure 11 B Installing disconnect chain on Opera-J

4.3 CLUTCH ADJUSTMENT

1. Adjustment of clutch is done by rotating the nut located at the end of the input shaft where the pulley 7" is located (Figure 12).
2. Rotate the nut counter-clockwise until there is insufficient tension to permit clutch to drive door.
3. Rotate the nut clockwise gradually until there is just enough tension on clutch to permit operator to move door smoothly, but to allow clutch to slip if door is obstructed.
4. When clutch is properly adjusted it should be possible to stop door by hand during travel.

**WARNING**

THE FRICTION CLUTCH IS DESIGNED TO PROTECT VEHICLES AND DOOR HARDWARE AGAINST DAMAGE. IT IS NOT INTENDED TO PROTECT PEOPLE. ALL DOORS SERVING PERSONNEL ARE TO BE FITTED WITH AN APPROPRIATE REVERSING DEVICE OR REVERSING EDGE TO PREVENT INJURY OR DEATH.

We strongly recommend the use of an automatic reversing device. Several types are available as accessories. Consult your dealer for a recommendation

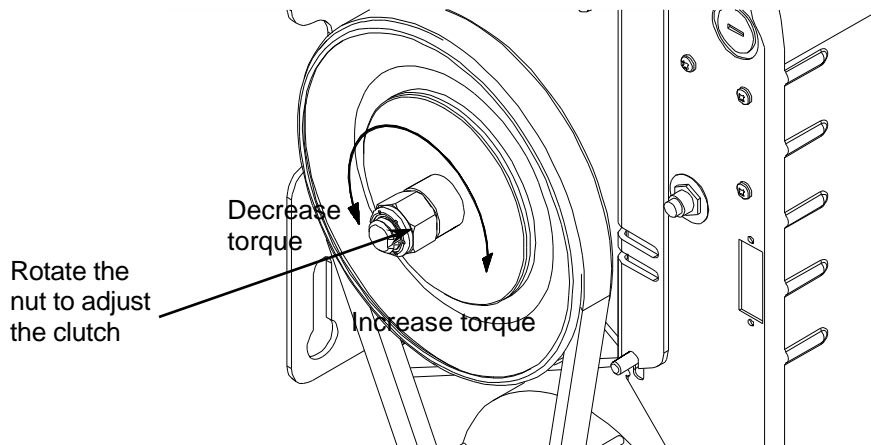

Figure 12 Clutch adjustment

4.4 ADJUSTMENT OF LIMIT SWITCHES



WARNING

NEVER PLACE HANDS OR TOOLS INSIDE OPERATOR OR NEAR DRIVE MECHANISM UNLESS POWER IS OFF

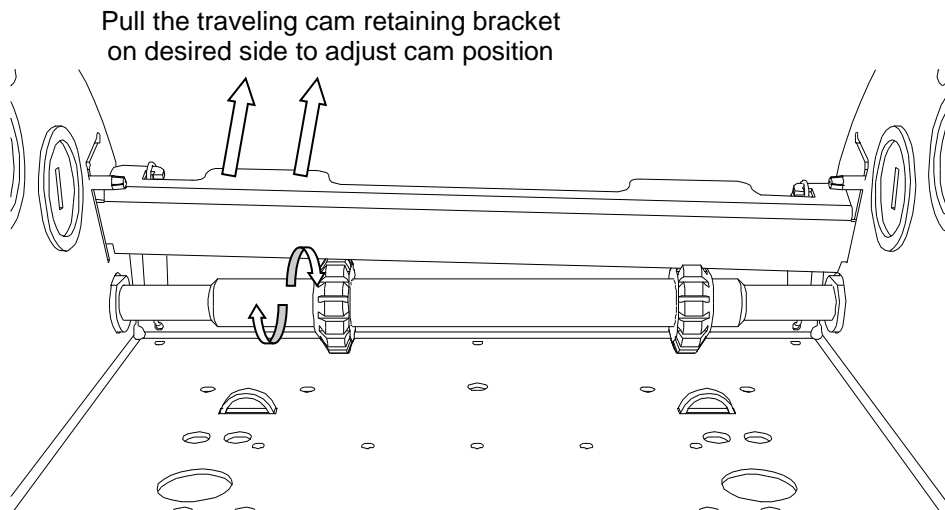

Figure 13 Adjusting the limit cams

1. Open the cover of the electrical enclosure.
2. Manually raise the door to a nearly opened position
3. Pull the travelling cam retaining bracket on the *Open Position cam* side and rotate the *Open Position cam* (Figure13).

Note: Turning the cam towards the center of the shaft increases door travel.

Turning the cam towards the switch decreases door travel.

4. Manually rotate the *Open Position cam* until the lever activates the *Open* limit switch sufficiently so as to hear the switch click.
5. Release and engage the retaining bracket. Make sure that the bracket engages in the slots **of both limit cams** after each adjustment.
6. Manually lower the door to a nearly closed position and repeat steps 3 through 5 with the *Close Position cam*.
7. Upon completion of all wiring connections, repeat steps 2 through 6 using the "Stop" button for adjustments of limit switches to their final, exact positions.

4.5 MINIMUM SUGGESTED WIRE SIZE FOR CONTROL CIRCUIT

The control circuit operates at 24 VAC. Due to the resistance in the wire used to carry the control circuit voltage, it is important to use the appropriate wire size with respect to the distance between the operator and the push-button station.

The chart (TABLE 2) indicating the minimum recommended wire size with respect to the total distance between the operator and the push-button station. DO NOT exceed the maximum distance. If there are several push-button stations in series you must ADD all these distances before selecting the appropriate wire gauge for your operator.

If the wire gauge is not suitable for the distance, problems in operation will be encountered such as chattering relays and contactor, premature wear of the contacts and possible tripping of the motor's thermal protection.

If a greater distance is required, a long distance interface module is suggested (consult factory).

When large gauge wire is used, a separate junction box will be needed for operator power connection (not supplied).

All power wiring to the operator should be installed by a qualified electrician and may vary with respect to conduit size and type as specified in the National Electrical Code, Article 430, allowing 5% voltage drop. Power must also be connected in accordance with local codes.

TABLE 2 WIRE SIZE v/s DISTANCE

24 VAC CONTROL WIRING	
Minimum suggested Wire gauge (AWG)	Maximum distance between operator and all Push-button stations feet (meters)
22	50 (15)
20	100 (30)
18	150 (45)
16	250 (75)
14	350 (105)
12	450 (135)

4.6 ADJUSTMENT AND MANUAL OPERATION OF OPERATORS

• Opera-H

The Opera-H operator is equipped with an automatic emergency chain hoist disconnect mechanism to operate the door manually, no floor disconnect is required.

In one simple step

- Control circuit interrupted.
- Coupling and hoist engaged.
- Manual operations.

are successively completed by pulling the hand chain in the desired direction:

1. Simply pull on the hand chain in the desired direction. The first foot pulled will engage the hoist mechanism and open the electrical circuit.
2. Continue the traction movement to move the door. If it doesn't run in the desired direction, repeat actions 1 and 2 by pulling the chain in the other direction (See Figure 14).
3. The automatic hoist engagement system is adjusted in the factory. It may require adjustment in the field. Adjustment is necessary if no door movement occurs after two fetes of pulled hand chain. Turn the adjusting nut clockwise (see figure 15) by $\frac{1}{4}$ turn until the hoist engages after pulling one foot of chain. If the nut is too tight, the manual torque on the chain will be too heavy.
4. Return to the standard electrical operation.

• Opera-J

- 1- Pull on the disconnect chain until feel a resistance.
- 2- Engage the chain in the chain keeper. The door is disconnected from the electrical motor and ready to be manually operated.
- 3- Just make free the disconnect chain from the chain keeper to "reconnect" the operator and return the standard electrical operation.

IMPORTANT: To return to electrical operation merely pull slightly on the opposite direction of the chain.



WARNING

DO NOT ATTEMPT TO DISENGAGE THE OPERATOR WHILE OPERATOR IS RUNNING. DO NOT ATTEMPT TO MANUALLY FORCE A MALFUNCTIONING DOOR TO OPEN OR CLOSE. THIS IS AN EMERGENCY DEVICE AND IS NOT DESIGNED TO OPERATE A DOOR WITH SERIOUS MECHANICAL PROBLEMS.

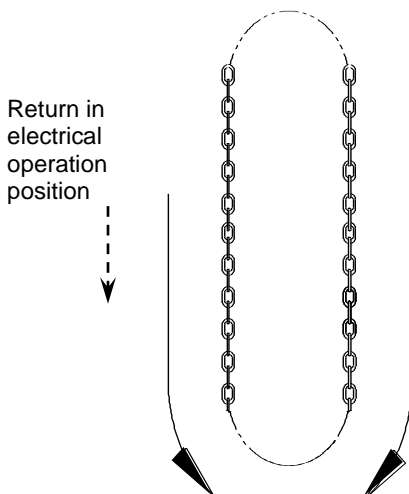

Engagement

Operation



Figure 14 Operating chain to open and close door

Figure 15 Manual operation system adjustment

5 SCHEDULED MAINTENANCE

Maintenance and supervision should be performed by qualified persons only. Inspection and service should be performed anytime a malfunction is observed or suspected.



WARNING

WHEN SERVICING - ALWAYS DISCONNECT OPERATOR FROM POWER SUPPLY

5.1 MECHANICAL

The door area should always be kept clear of dirt, rocks or any other substance to insure proper operation.

EVERY 3 MONTHS	- Check and adjust the clutch, if necessary.
EVERY 6 MONTHS	- Lubricate all moving parts, Bushing are oil impregnated and are lubricated for life. - Verify that all mechanical parts function properly. - Inspect the V-belt and adjust or replace if necessary. - Manually operate the door. If the door does not open or close freely, correct the cause of the malfunction.
ONCE A YEAR	- Inspect all bolts and screws and tighten if necessary. - Check for any excessive slack in chains and adjust or replace them if necessary. The limit switches may have to be reset after a chain adjustment. - Inspect the door for wear and damage. - Run the operator a few cycles: Make sure that the door rollers are rolling smoothly on the track. Listen to the motor: The motor should hum quietly and smoothly. Verify that the limit operates quietly and smoothly: investigate any unusual noise. - Verify that the mooring bolts are holding the unit securely. - Inspect the unit for evidence of corrosion.

5.2 ELECTRICAL



WARNING

BEFORE OPENING THE CONTROL BOX COVER, DISCONNECT OPERATOR FROM POWER SUPPLY

- Inspect the unit for evidence of corrosion.
- Inspect the wiring compartment and remove any dirt from the control units.
- Check all the grounding wires and terminations for corrosion. Be particularly careful to check the ground wires.
- Check the terminal strip to insure that all the screws are tight.
- Verify that the safety edge or other safety devices installed on the operator are fully operational.
- Check the voltage at the input terminals while the operator is running. The voltage must not drop more than 10% momentarily. If the voltage drop is too deep when running, the relays may chatter, the contact points will wear prematurely and may eventually weld. Check the power terminations for corrosion.
- Check the current consumption of the unit with an amp-meter. The value of current should be consistent with the nameplate specifications. Investigate any anomaly.

6. Opera-H exploded view

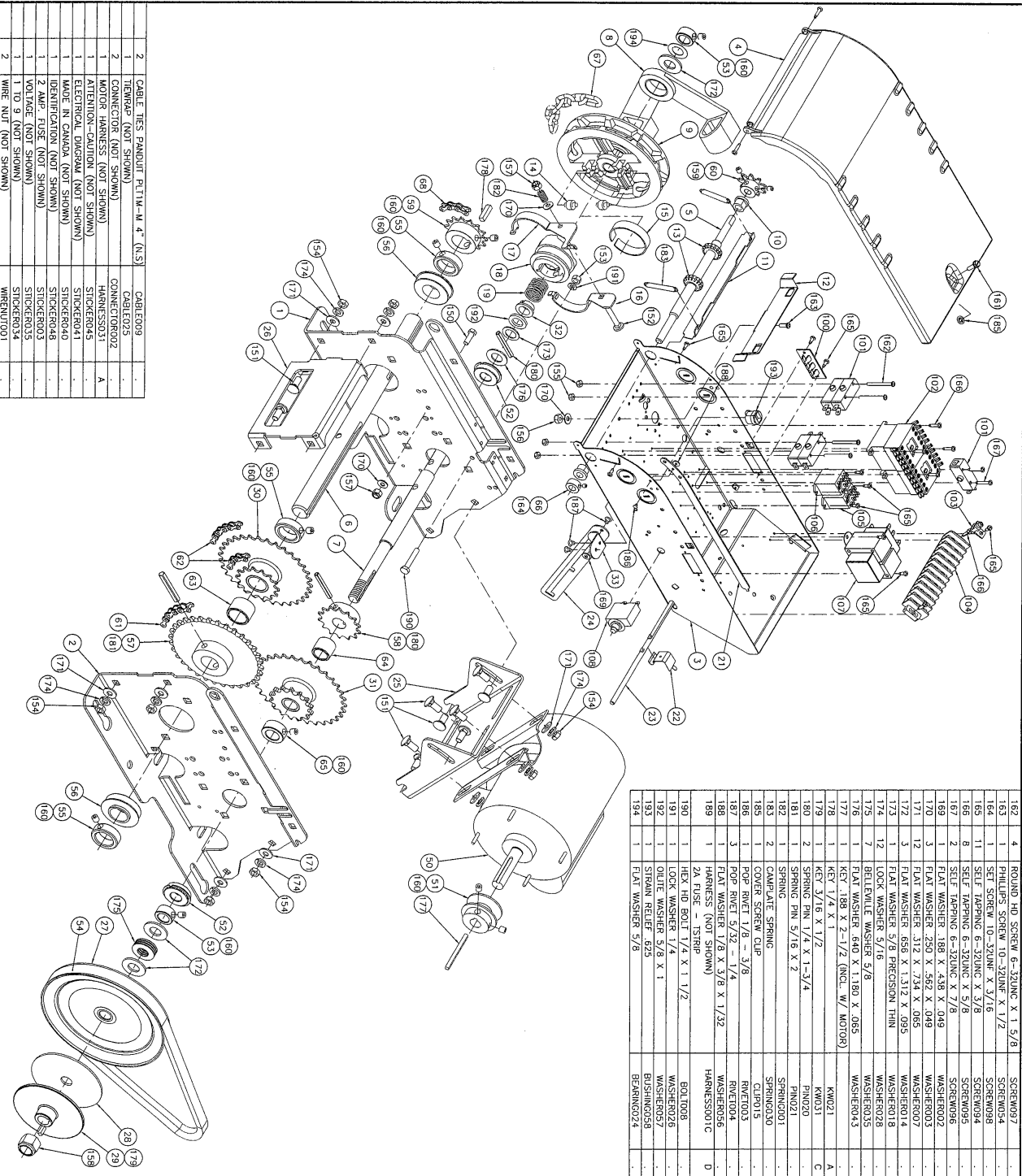

PARTS IDENTIFICATION		#	QTY	DESCRIPTION	#	MANUFACTURER	REV
162	4	1	1	ROUND HD SCREW 6-32UNC X 1 5/8	1	FRAMER037	M
163	1	1	1	PHILLIPS SCREW 10-32UNC X 1 1/2	1	FRAMER038	M
164	1	2	1	SET SCREW 10-32UNC X 3/16	2	FRAMER039	M
165	11	2	1	SELF TAPPING 6-32UNC X 5/8	2	FRAMER040	M
166	8	5	1	SELF TAPPING 6-32UNC X 5/8	5	FRAMER041	M
167	2	1	1	SELF TAPPING 6-32UNC X 5/8	1	FRAMER042	M
168	3	1	1	FLAT WASHER 188 X 4.8 X 1.049	1	FRAMER043	M
169	3	1	1	FLAT WASHER 250 X 5.62 X 1.049	1	FRAMER044	M
170	12	7	1	FLAT WASHER 312 X 7.24 X .085	7	FRAMER045	M
171	3	1	1	FLAT WASHER 656 X 1.312 X .085	1	FRAMER046	M
172	1	1	1	FLAT WASHER 5/8 PRECISION THIN	1	FRAMER047	M
173	12	9	1	LOOK WASHER 5/16	9	FRAMER048	M
174	1	10	2	BELENVILLE WASHER 5/8	2	FRAMER049	M
175	7	11	1	FLAT WASHER 640 X 1.190 X .085	11	FRAMER050	M
176	1	1	1	KEY .188 X 2-1/2 (INCL. W/ MOTOR)	1	FRAMER051	M
177	1	1	1	KEY 1/4 X 1	1	FRAMER052	M
178	1	1	1	KEY 3/16 X 1 1/2	1	FRAMER053	M
179	2	1	1	SPRING PIN 1/4 X 1-3/4	1	FRAMER054	M
180	1	1	1	SPRING PIN 5/16 X 2	1	FRAMER055	M
181	2	1	1	CAM PLATE SPRING	1	FRAMER056	M
182	1	1	1	COIL SPRING	1	FRAMER057	M
183	1	1	1	COIL SPRING	1	FRAMER058	M
184	1	1	1	POP RIVET 5/32 - 1/4	1	FRAMER059	M
185	1	1	1	POP RIVET 5/32 - 1/4	1	FRAMER060	M
186	1	1	1	FLAT WASHER 1/8 X 3/8 X 1/32	1	FRAMER061	M
187	1	1	1	HARNESSTIC - 13TRIP	1	FRAMER062	M
188	1	1	1	HEX HD BOLT 1/4 X 1 1/2	1	FRAMER063	M
189	1	1	1	LOCK WASHER 1/4	1	FRAMER064	M
190	1	1	1	OLIVE WASHER 5/8 X 1	1	FRAMER065	M
191	1	1	1	STRAIN RELIEF 625	1	FRAMER066	M
192	1	1	1	FLAT WASHER 5/8	1	FRAMER067	M
193	1	1	1	FLAT WASHER 5/8	1	FRAMER068	M
194	1	1	1	FLAT WASHER 5/8	1	FRAMER069	M
1	1	1	1	LEFT HAND SIDE FRAME	1	FRAMER070	M
2	1	1	1	RIGHT HAND SIDE FRAME	1	FRAMER071	M
3	1	1	1	CONTROL BOX	1	FRAMER072	M
4	1	1	1	INPUT SHAFT	1	FRAMER073	M
5	1	1	1	OUTPUT SHAFT	1	FRAMER074	M
6	1	1	1	INPUT SHAFT	1	FRAMER075	M
7	1	1	1	CHAIN GUIDE	1	FRAMER076	M
8	1	1	1	HAND SHAFT PULLEY	1	FRAMER077	M
9	1	1	1	HAND SHAFT PULLEY	1	FRAMER078	M
10	2	1	1	CAMPLATE	1	FRAMER079	M
11	1	1	1	LIMIT SWITCH LEVER	1	FRAMER080	M
12	1	1	1	LIMIT CAM	1	FRAMER081	M
13	2	1	1	ROLLER	1	FRAMER082	M
14	2	1	1	FRICTION BAND	1	FRAMER083	M
15	1	1	1	SWITCH SHOE	1	FRAMER084	M
16	1	1	1	CAM DISCONNECT	1	FRAMER085	M
17	1	1	1	COVER ANV SPRING	1	FRAMER086	M
18	1	1	1	COVER ANV SPRING	1	FRAMER087	M
19	1	1	1	COIL SPRING	1	FRAMER088	M
20	1	1	1	COIL SPRING	1	FRAMER089	M
21	1	1	1	COIL SPRING	1	FRAMER090	M
22	1	1	1	COIL SPRING	1	FRAMER091	M
23	1	1	1	COIL SPRING	1	FRAMER092	M
24	1	1	1	COIL SPRING	1	FRAMER093	M
25	1	1	1	COIL SPRING	1	FRAMER094	M
26	1	1	1	HANDLE	1	FRAMER095	M
27	1	1	1	DRAWN PULLEY SL X 7"	1	FRAMER096	M
28	1	1	1	CL.PAD 5/8x4x1"	1	FRAMER097	M
29	1	1	1	CLUTCH PLATE OPERA	1	FRAMER098	M
30	1	1	1	DOUBLE SPRCKET	1	FRAMER099	M
31	1	1	1	DOUBLE SPRCKET	1	FRAMER100	M
32	1	1	1	DISCONNECT SPRING BUSHING	1	FRAMER101	M
33	1	1	1	COXY ARM L-BRACKET	1	FRAMER102	M
34	1	1	1	MOTOR PULLEY SL X 2"	1	FRAMER103	M
35	1	1	1	SPALD TUNAGED BRG 5/8 PRECISION	1	FRAMER104	M
36	1	1	1	COLLAR 1/2"	1	FRAMER105	M
37	1	1	1	COLLAR 1/2" (WITH HARNESSTIC)	1	FRAMER106	M
38	1	1	1	COLLAR 1/2" (WITH CHAIN LINK)	1	FRAMER107	M
39	1	1	1	COLLAR 1/2" (WITH CHAIN LINK)	1	FRAMER108	M
40	1	1	1	COLLAR 1/2" (WITH CHAIN LINK)	1	FRAMER109	M
41	1	1	1	COLLAR 1/2" (WITH CHAIN LINK)	1	FRAMER110	M
42	1	1	1	COLLAR 1/2" (WITH CHAIN LINK)	1	FRAMER111	M
43	1	1	1	COLLAR 1/2" (WITH CHAIN LINK)	1	FRAMER112	M
44	1	1	1	COLLAR 1/2" (WITH CHAIN LINK)	1	FRAMER113	M
45	1	1	1	COLLAR 1/2" (WITH CHAIN LINK)	1	FRAMER114	M
46	1	1	1	COLLAR 1/2" (WITH CHAIN LINK)	1	FRAMER115	M
47	1	1	1	COLLAR 1/2" (WITH CHAIN LINK)	1	FRAMER116	M
48	1	1	1	COLLAR 1/2" (WITH CHAIN LINK)	1	FRAMER117	M
49	1	1	1	COLLAR 1/2" (WITH CHAIN LINK)	1	FRAMER118	M
50	1	1	1	COLLAR 1/2" (WITH CHAIN LINK)	1	FRAMER119	M
51	1	1	1	COLLAR 1/2" (WITH CHAIN LINK)	1	FRAMER120	M
52	1	1	1	COLLAR 1/2" (WITH CHAIN LINK)	1	FRAMER121	M
53	1	1	1	COLLAR 1/2" (WITH CHAIN LINK)	1	FRAMER122	M
54	1	1	1	COLLAR 1/2" (WITH CHAIN LINK)	1	FRAMER123	M
55	1	1	1	COLLAR 1/2" (WITH CHAIN LINK)	1	FRAMER124	M
56	1	1	1	COLLAR 1/2" (WITH CHAIN LINK)	1	FRAMER125	M
57	1	1	1	COLLAR 1/2" (WITH CHAIN LINK)	1	FRAMER126	M
58	1	1	1	COLLAR 1/2" (WITH CHAIN LINK)	1	FRAMER127	M
59	1	1	1	COLLAR 1/2" (WITH CHAIN LINK)	1	FRAMER128	M
60	1	1	1	COLLAR 1/2" (WITH CHAIN LINK)	1	FRAMER129	M
61	1	1	1	COLLAR 1/2" (WITH CHAIN LINK)	1	FRAMER130	M
62	1	1	1	COLLAR 1/2" (WITH CHAIN LINK)	1	FRAMER131	M
63	1	1	1	COLLAR 1/2" (WITH CHAIN LINK)	1	FRAMER132	M
64	1	1	1	COLLAR 1/2" (WITH CHAIN LINK)	1	FRAMER133	M
65	1	1	1	COLLAR 1/2" (WITH CHAIN LINK)	1	FRAMER134	M
66	1	1	1	COLLAR 1/2" (WITH CHAIN LINK)	1	FRAMER135	M
67	1	1	1	COLLAR 1/2" (WITH CHAIN LINK)	1	FRAMER136	M
68	1	1	1	COLLAR 1/2" (WITH CHAIN LINK)	1	FRAMER137	M
69	1	1	1	COLLAR 1/2" (WITH CHAIN LINK)	1	FRAMER138	M
70	1	1	1	COLLAR 1/2" (WITH CHAIN LINK)	1	FRAMER139	M
71	1	1	1	COLLAR 1/2" (WITH CHAIN LINK)	1	FRAMER140	M
72	1	1	1	COLLAR 1/2" (WITH CHAIN LINK)	1	FRAMER141	M
73	1	1	1	COLLAR 1/2" (WITH CHAIN LINK)	1	FRAMER142	M
74	1	1	1	COLLAR 1/2" (WITH CHAIN LINK)	1	FRAMER143	M
75	1	1	1	COLLAR 1/2" (WITH CHAIN LINK)	1	FRAMER144	M
76	1	1	1	COLLAR 1/2" (WITH CHAIN LINK)	1	FRAMER145	M
77	1	1	1	COLLAR 1/2" (WITH CHAIN LINK)	1	FRAMER146	M
78	1	1	1	COLLAR 1/2" (WITH CHAIN LINK)	1	FRAMER147	M
79	1	1	1	COLLAR 1/2" (WITH CHAIN LINK)	1	FRAMER148	M
80	1	1	1	COLLAR 1/2" (WITH CHAIN LINK)	1	FRAMER149	M
81	1	1	1	COLLAR 1/2" (WITH CHAIN LINK)	1	FRAMER150	M
82	1	1	1	COLLAR 1/2" (WITH CHAIN LINK)	1	FRAMER151	M
83	1	1	1	COLLAR 1/2" (WITH CHAIN LINK)	1	FRAMER152	M
84	1	1	1	COLLAR 1/2" (WITH CHAIN LINK)	1	FRAMER153	M
85	1	1	1	COLLAR 1/2" (WITH CHAIN LINK)	1	FRAMER154	M
86	1	1	1	COLLAR 1/2" (WITH CHAIN LINK)	1	FRAMER155	M
87	1	1	1	COLLAR 1/2" (WITH CHAIN LINK)	1	FRAMER156	M
88	1	1	1	COLLAR 1/2" (WITH CHAIN LINK)	1	FRAMER157	M
89	1	1	1	COLLAR 1/2" (WITH CHAIN LINK)	1	FRAMER158	M
90	1	1	1	COLLAR 1/2" (WITH CHAIN LINK)	1	FRAMER159	M
91	1	1	1	COLLAR 1/2" (WITH CHAIN LINK)	1	FRAMER160	M
92	1	1	1	COLLAR 1/2" (WITH CHAIN LINK)	1	FRAMER161	M
93	1	1	1	COLLAR 1/2" (WITH CHAIN LINK)	1	FRAMER162	M
94	1	1	1	COLLAR 1/2" (WITH CHAIN LINK)	1	FRAMER163	M
95	1	1	1	COLLAR 1/2" (WITH CHAIN LINK)	1	FRAMER164	M
96	1	1	1	COLLAR 1/2" (WITH CHAIN LINK)	1	FRAMER165	M
97	1	1	1	COLLAR 1/2" (WITH CHAIN LINK)	1	FRAMER166	M
98	1	1	1	COLLAR 1/2" (WITH CHAIN LINK)	1	FRAMER167	M
99	1	1	1	COLLAR 1/2" (WITH CHAIN LINK)	1	FRAMER168	M
100	1	1	1	COLLAR 1/2" (WITH CHAIN LINK)	1	FRAMER169	M
101	1	1	1	COLLAR 1/2" (WITH CHAIN LINK)	1	FRAMER170	M
102	1	1	1	COLLAR 1/2" (WITH CHAIN LINK)	1	FRAMER171	M
103	1	1	1	COLLAR 1/2" (WITH CHAIN LINK)	1	FRAMER172	M
104	1	1	1	COLLAR 1/2" (WITH CHAIN LINK)	1	FRAMER173	M
105	1	1	1	COLLAR 1/2" (WITH CHAIN LINK)	1	FRAMER174	M
106	1	1	1	COLLAR 1/2" (WITH CHAIN LINK)	1	FRAMER175	M
107	1	1	1	COLLAR 1/2" (WITH CHAIN LINK)	1	FRAMER176	M
108	1	1	1	COLLAR 1/2" (WITH CHAIN LINK)	1	FRAMER177	M
109	1	1	1	COLLAR 1/2" (WITH CHAIN LINK)	1	FRAMER178	M
110	1	1	1	COLLAR 1/2" (WITH CHAIN LINK)	1	FRAMER179	M
111	1	1	1	COLLAR 1/2" (WITH CHAIN LINK)	1	FRAMER180	M
112	1	1	1	COLLAR 1/2" (WITH CHAIN LINK)	1	FRAMER181	M
113	1	1	1	COLLAR 1/2" (WITH CHAIN LINK)	1	FRAMER182	M
114	1	1	1	COLLAR 1/2" (WITH CHAIN LINK)	1	FRAMER183	M
115	1	1	1	COLLAR 1/2" (WITH CHAIN LINK)	1	FRAMER184	M
116	1	1	1	COLLAR 1/2" (WITH CHAIN LINK)	1	FRAMER185	M
117	1	1	1	COLLAR 1/2" (WITH CHAIN LINK)	1	FRAMER186	M
118	1	1	1	COLLAR 1/2" (WITH CHAIN LINK)	1	FRAMER187	M
119	1	1	1	COLLAR 1/2" (WITH CHAIN LINK)	1	FRAMER188	M
120	1	1	1	COLLAR 1/2" (WITH CHAIN LINK)	1	FRAMER189	M
121	1	1	1	COLLAR 1/2" (WITH CHAIN LINK)	1	FRAMER190	M
122	1	1	1	COLLAR 1/2" (WITH CHAIN LINK)	1	FRAMER191	M
123	1	1	1	COLLAR 1/2" (WITH CHAIN LINK)	1	FRAMER192	M
124							

6.1 Opera-J exploded view

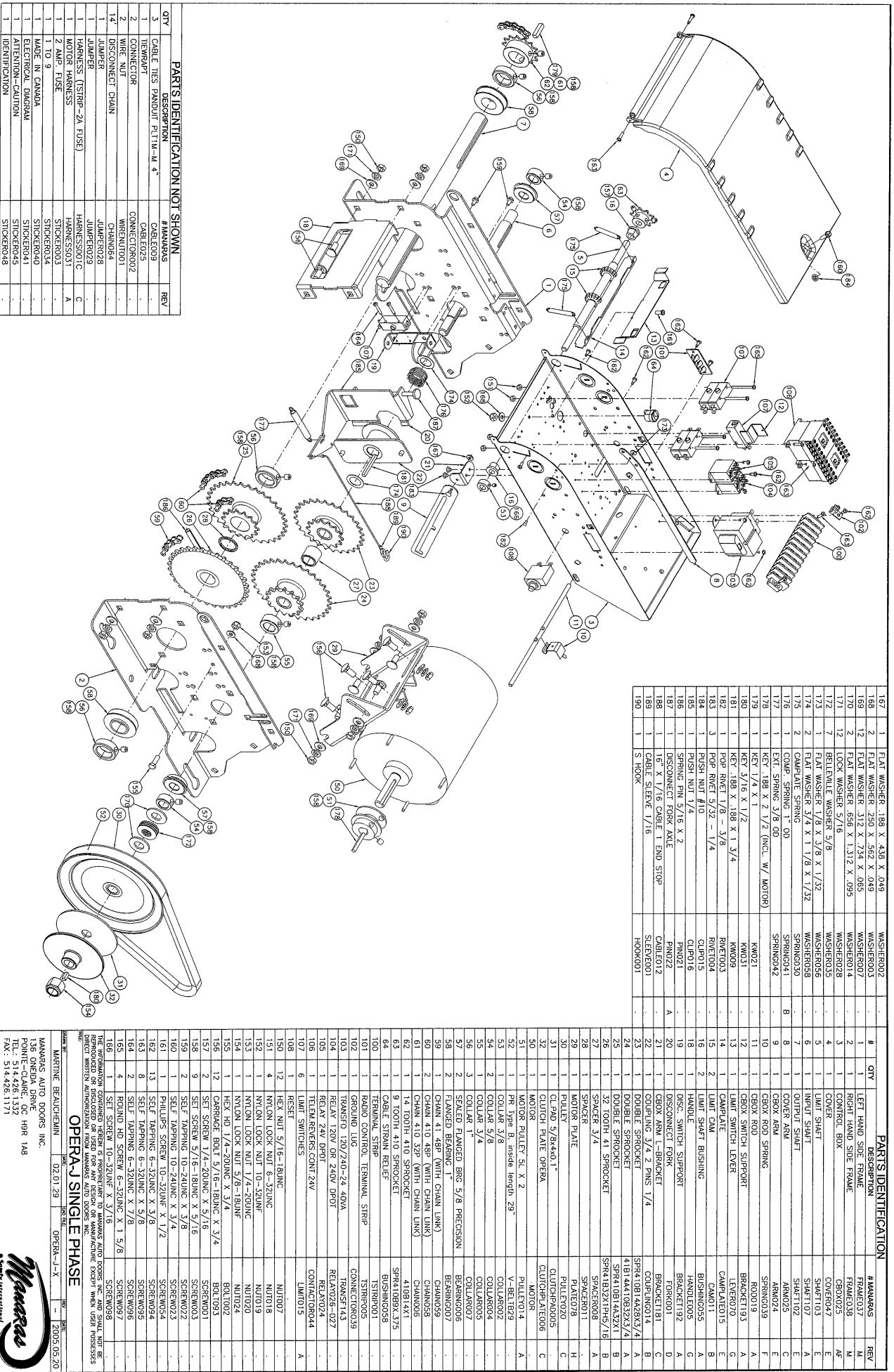

QTY	DESCRIPTION	#MAMAKAS	REV
167	1	FLAT WASHER .189 X .438 X .049	WASHER002
168	2	FLAT WASHER .250 X .562 X .049	WASHER003
169	12	FLAT WASHER .312 X .734 X .065	WASHER007
170	2	FLAT WASHER .656 X 1.312 X .095	WASHER014
171	12	LOCK WASHER 5/16	WASHER028
172	7	BELLEVILLE WASHER 5/8	WASHER035
173	1	FLAT WASHER 1/8 X 3/8 X 1/32	WASHER056
174	2	FLAT WASHER 3/4 X 1 1/8 X 1/32	WASHER058
175	2	COMP. SPRING	SPRING030
176	1	COMP. SPRING 1" OD	SPRING041
177	1	KEY SPRING 3/8 OD	SPRING042
178	1	KEY SPRING 2 1/2 (INCL. W/ MOTOR)	KNO21
179	1	KEY 1/8 X 1 1/2	KNO21
180	1	KEY 1/8 X 1 1/2	KNO21
181	1	KEY 1/8 X 1 1/2	KNO21
182	1	KEY 1/8 X 1 1/2	KNO21
183	3	POP RINET 1/8 - 3/8	ROET004
184	1	POP RINET 5/32 - 1/4	ROET004
185	1	PUSH NUT #10	CLUP016
186	1	PUSH NUT 1/4	CLUP016
187	1	SPRING PIN 5/16 X 2	PIN021
188	1	DISCONNECT FORK AXLE	PIN022
189	1	16" X 1/16 CABLE 1 END STOP	CABLE012
190	1	CABLE SLEEVE 1/16	SLEVE001
191	1	HOOK	HOOK001

PARTS IDENTIFICATION NOT SHOWN

QTY	DESCRIPTION	#MAMAKAS	REV
3	CABLE TIE PANDUIT PL114-M-4"	CABLE009	-
1	THEWRAPT	CABLE025	-
2	CONNECTOR	CONNECTOR02	-
14	DISCONNECT CHAIN	WIENUT001	-
1	JUMPER	JUMPER028	-
1	HARNESS (15STRIP-2A FUSE)	HARNESS010	C
1	MOTOR HARNESS	HARNESS011	A
1	2 AMP FUSE	STICKER003	-
1	1 TO 9	STICKER004	-
1	MADE IN CANADA	STICKER041	-
1	ELECTRICAL DIAGRAM	STICKER041	-
1	ATTENTION-CAUTION	STICKER045	-
1	IDENTIFICATION	STICKER048	-

PARTS IDENTIFICATION

#	QTY	DESCRIPTION	#MAMAKAS	REV
1	1	LEFT HAND SIDE FRAME	FRAM037	M
2	1	RIGHT HAND SIDE FRAME	FRAM038	M
3	1	CONTROL BOX	CB0X025	AF
4	1	COVER	COVER047	AF
5	1	LIMIT SWITCH	SHAF0103	E
6	1	INPUT SHIRT	SHAF0102	A
7	1	OUTPUT SHIRT	SHAF0102	A
8	1	COVER ASM	ARM025	C
9	1	COVER ASM	ARM025	C
10	1	GEAR ROD SPRING	SPRING038	F
11	1	GEAR SWITCH SUPPORT	BRACKET183	A
12	1	GEAR SWITCH SUPPORT	BRACKET183	A
13	1	LIMIT SWITCH LEVER	LEVER070	G
14	1	CAM PLATE	CAMP10115	E
15	1	LIMIT CAM	CAMP0111	B
16	2	LIMIT SHIRT BUSHING	BUSHING055	B
17	2	HANDLE	HANDLE055	A
18	1	DISC. SWITCH SUPPORT	BRACKET192	A
19	1	DISCONNECT FORK	FORK001	D
20	1	COUPLING 3/4 2 PINS 1/4	BRACKET181	C
21	1	COUPLING 3/4 2 PINS 1/4	COUPLING014	B
22	1	DOUBLE SPRCKET	SPR410814A283/4	A
23	1	DOUBLE SPRCKET	SPR410814A283/4	A
24	1	DOUBLE SPRCKET	SPR410814A283/4	A
25	2	32 TOOTH 41 SPRCKET	SPR41832X178/16	B
26	1	SPACER 3/4	SPACER008	A
27	1	SPACER 3/4	SPACER008	A
28	1	SPACER PLATE	SPACER011	A
29	1	PULLER	PULLER026	H
30	1	CLIP 5/8x40-1"	CLIP058005	C
31	1	GLITCH PLATE OPERA	GLITCHPLATE006	C
32	1	MOTOR	MOTOR	C
50	1	PULLER	PULLER014	A
51	1	PRE Type B, inside length 29"	V-BELT029	A
52	1	COLLAR 3/8	COLLAR002	C
53	1	COLLAR 5/8	COLLAR004	C
54	2	COLLAR 3/4	COLLAR005	C
55	1	COLLAR 1"	COLLAR007	C
56	3	SEALED FLANGED BRG 5/8 PRECISION	BEARING006	-
57	2	CHAM 41 48P (WITH CHAIN LINK)	BEARING007	-
58	2	CHAM 41 48P (WITH CHAIN LINK)	BEARING007	-
59	2	CHAM 41 48P (WITH CHAIN LINK)	BEARING007	-
60	2	CHAM 41 48P (WITH CHAIN LINK)	BEARING007	-
61	2	CHAM 41 48P (WITH CHAIN LINK)	BEARING007	-
62	1	14 TOOTH 410 SPRCKET	SPR410810X375	A
63	1	9 TOOTH 410 SPRCKET	SPR410809X375	A
64	1	CABLE STRAIN RELIEF	BUSHING058	-
100	1	TERMINAL STRIP	ISIRIP001	-
101	1	RADIO CONTROL TERMINAL STRIP	ISIRIP001	-
102	1	GROUND LUG	CONNECTOR039	-
103	1	TRANSFO 120/240-24 40VA	TRANSF143	-
104	1	RELAY 120V DR 240V DPDT	RELAY028-027	-
105	1	RELAY 24V DPDT	RELAY024	-
106	1	TELEM REVERS CONT 24V	CONTACTOR044	-
107	6	LIMIT SWITCHES	LIMIT015	A
108	12	RESET	NOJ007	-
109	12	HEX NUT 5/16-18UNC	NOJ018	-
110	4	NYLON LOCK NUT 6-32UNC	NOJ018	-
111	4	NYLON LOCK NUT 10-32UNC	NOJ019	-
112	1	NYLON LOCK NUT 1/8-18UNC	NOJ020	-
113	1	NYLON LOCK NUT 1/8-18UNC	NOJ020	-
114	1	HEX HD 1/4-20UNC X 3/4	ROL1002	-
115	1	HEX HD 1/4-20UNC X 3/4	ROL1003	-
116	12	CARRIAGE BOLT 5/16-18UNC X 3/4	ROL1003	-
117	2	SET SCREW 5/16-18UNC X 5/16	SCREW001	-
118	9	SET SCREW 1/4-20UNC X 5/16	SCREW003	-
119	2	SELF TAPPING 10-24UNC X 5/8	SCREW022	-
120	1	SELF TAPPING 10-24UNC X 3/4	SCREW023	-
121	1	PHILLIPS SCREW 10-32UNC X 1/2	SCREW054	-
122	1	SELF TAPPING 6-32UNC X 3/8	SCREW094	-
123	13	SELF TAPPING 6-32UNC X 3/8	SCREW095	-
124	8	SELF TAPPING 6-32UNC X 5/8	SCREW096	-
125	4	ROUND HD SCREW 6-32UNC X 7/8	SCREW097	-
126	1	SET SCREW 10-32UNC X 3/16	SCREW098	-

OPERAJ SINGLE PHASE

OPERAJ IS A TRADE NAME OF MAMAKAS AUTO DOORS INC. AND SHALL NOT BE REPRODUCED OR RESOLD IN ANY MANNER WITHOUT THE WRITTEN AUTHORIZATION FROM MAMAKAS AUTO DOORS INC. DIRECT WRITTEN AUTHORIZATION FROM MAMAKAS AUTO DOORS INC.

DATE: 02-01-29

OPERAJ-1X

SCALE: 2:000 (05.20)

WARTIME BEAUCHEMIN

MAMAKAS AUTO DOORS INC.
 1380 DENVER DRIVE
 HBR 148
 TEL: 514-426-1332
 FAX: 514-426-1171

7. Specific section for operators supplied with

ELECTRONIC CONTROL BOARD (ECB)

- 7.1 POWER AND CONTROL WIRING DIAGRAM**
- 7.2 ELECTRONIC CIRCUIT BOARD**
- 7.3 PROGRAM SETTING**
- 7.4 MODE SETTING**
- 7.5 CONNECTION OF REVERSING EDGE**
- 7.6 DOOR INTERLOCK & FRICTION CLUTCH**
- 7.9 TROUBLESHOOTING GUIDE**

NOTE: Please refer to page 29 for hardwired operators.

7.1 POWER AND CONTROL WIRING DIAGRAM

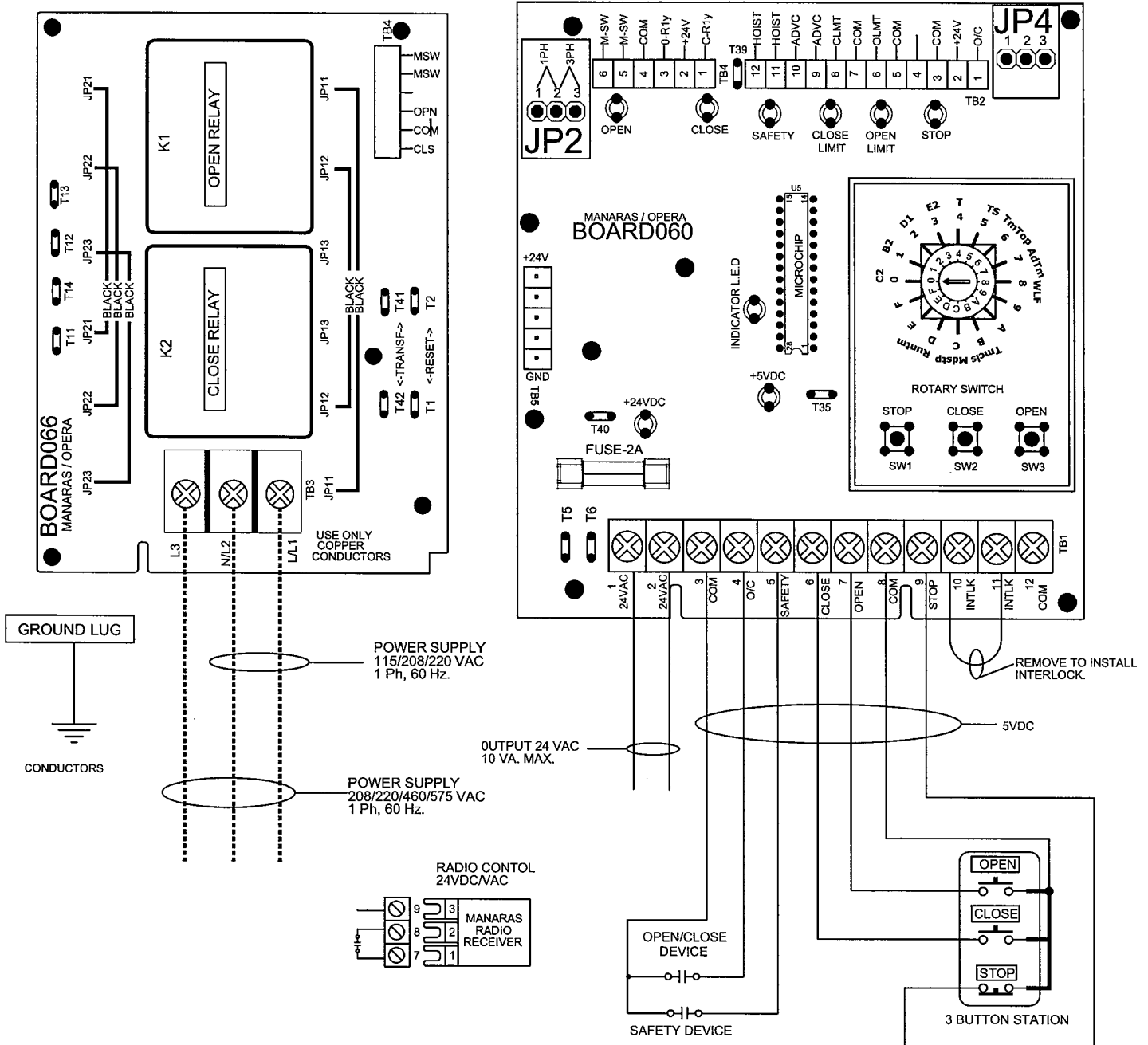

VERY IMPORTANT NOTES

⚠ Before installing power and control wiring, be sure to follow all specifications described below. Failure to do so may damage the operator.

- The operator must be properly grounded and connected in accordance to local electrical codes.
- Use different knockouts available on EACH side of the control box to pass the power and control wiring through.
- Ensure maximum separation between power wiring and low voltage control wirings in the control box.
- Please refer to next page for details.



- If a push button is not used, a jumper must be placed between #8 & #9
***Under this condition a stop command is not available to stop the door during its travel.
- Please refer to Accessories Wiring diagrams (TN005E) before connecting any external accessories
- **2 Amp fuse** is used to protect 24VDC on electronic board and also the 24VAC supply for auxiliary control devices

LOW VOLTAGE (controls) AND HIGH VOLTAGE (power) WIRINGS.

Route the power line wires either from right or from left of the control box.

Route all low voltage control wires as shown. Keep low voltage wires separate from line voltage wires.

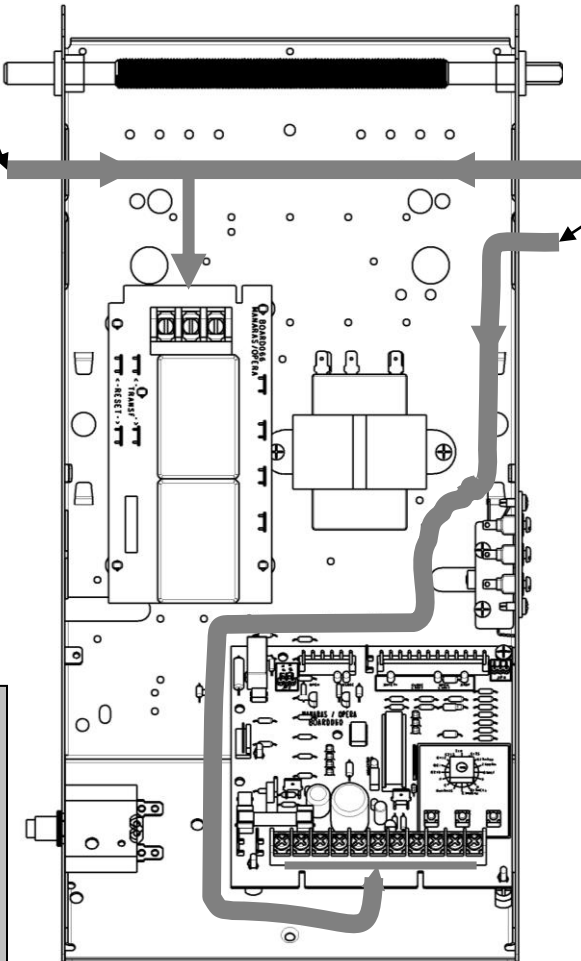

WARNING

- Wall control(s) must be located so that the door is within sight of the user.
- If momentary contact (B2 mode) is used, an external reversing device must be install.

Accessory Wiring

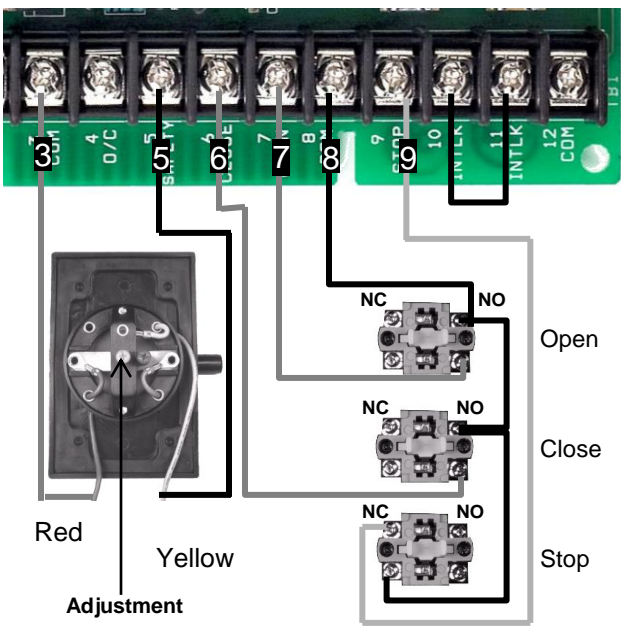

AIRSWITCH007

STATION031

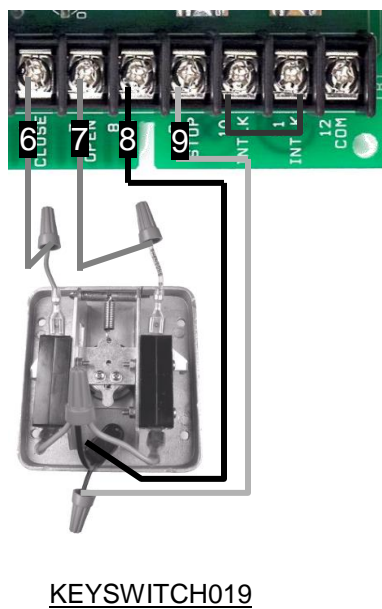

KEYSWITCH019

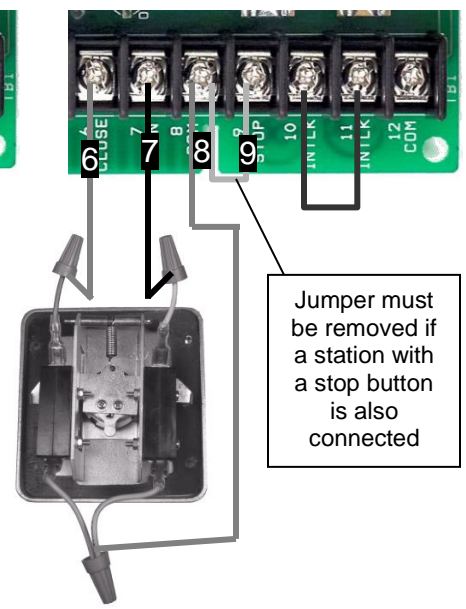

KEYSWITCH015

Jumper must be removed if a station with a stop button is also connected

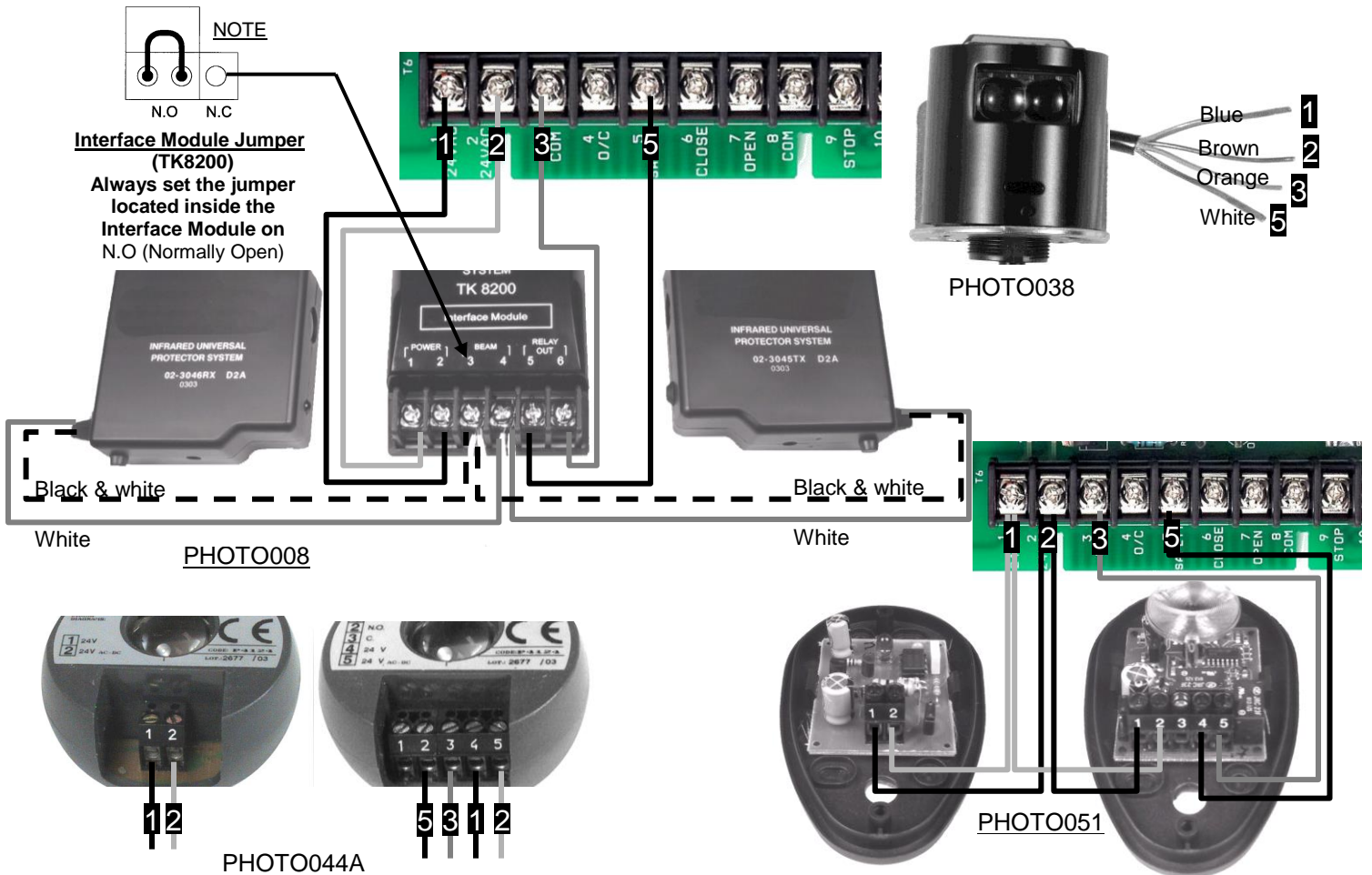
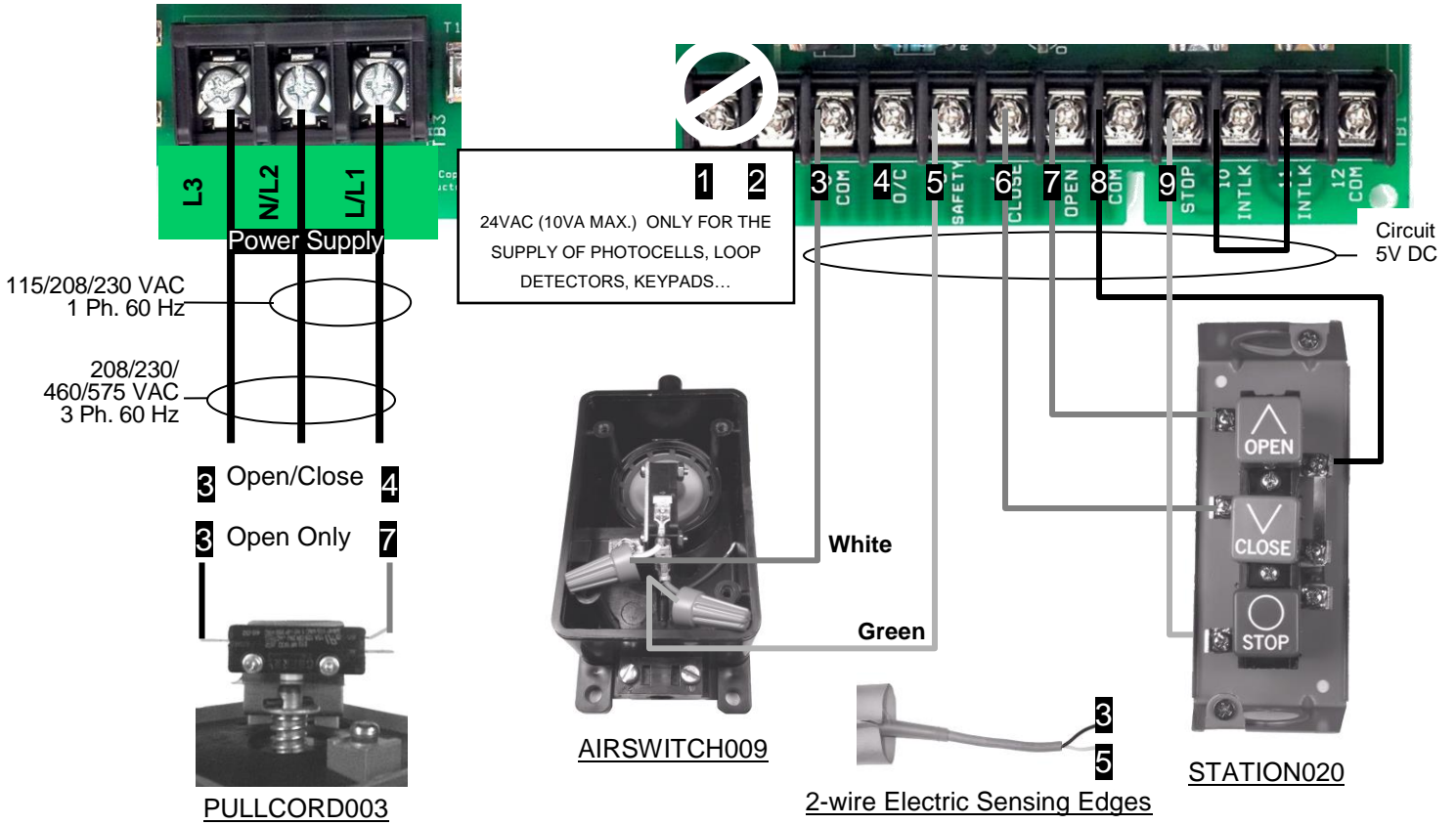

7.2 ELECTRONIC CONTROL BOARD

LED MONITORING STATUS

LED's on the ECB help with wiring and making troubleshooting diagnoses. Every LED states the actual position of the door. The board has a non-volatile memory and all the LED return to their initial state after a power interruption.

L.E.D	Color	STATUS
+24 V	Green	When ON indicates the presence of 24VDC on the Logic Board
+5 V	Green	When ON indicates the presence of 5VDC power in the Control Circuit
Open Limit	Red	When ON indicates door position, completely open.
Open	Red	Only when the open relay is activated (open relay is energized)
Close Limit	Red	When ON indicates door position, completely close.
Close	Red	Only when the close relay is activated (close relay is energized)
Safe	Red	Light ON only when safety devices are activated.
INDICAT (Wrong Handling)**	Red	Flashes only when motor runs in opposite direction and activates the wrong limit switch.
		Stay ON only when the "centrifugal switch" is opened (<i>please contact technical support</i>)
STOP	Yellow	In normal conditions light; stay ON, goes OFF every time when press STOP button or hoist is engaged

WRONG HANDLING

Wrong handling protection prevents the operator from over passing the limits when incoming 3-phase power or a single-phase motor are incorrectly connected.

When the operator turns in the opposite direction and reaches the wrong limit switch, the LED indicator flashes-on and all the external commands are ignored by the electronic board.

To correct the problem when:

Stop LED OFF:

- Check if the Stop button is properly connected on #8 and #9 or if a Normally Closed contact is used.
- Verify if the Hoist is properly engaged and if the Hoist switch is closed (or if any external interlock device is remained open)

EXTERNAL CONTROLS

Refer to the wiring diagram on page 18 before connecting power or any external device to the ECB. Neglecting to use the proper terminals will result in complete damage to the ECB. If you are not certain about procedures, please consult Manaras for assistance.

NOTE: Do not attempt correction by reversing wires on control station.



WARNING

WHEN REPLACING AN ELECTRONIC CONTROL BOARD DO CHECK THAT ALL JUMPERS ARE POSITIONED AS INDICATED IN THE WIRING DIAGRAMS ON PAGE 25 FOR SINGLE PHASE AND ON PAGE 26 FOR 3-PHASE.

PROGRAM AND PROGRAM SETTINGS



Programming ability and door control at electrical box are provided by Open/Close/Stop buttons and Select Switch located on the ECB.

• **Programs**

PROGRAMS	FUNCTIONS AND DESCRIPTIONS
RUN TIMER	The Run Timer stops automatically the operator after an adjustable time delay either travelling upwards or downwards. The Run Timer is designed to protect the door and the operator by preventing the motor over running much longer than the normal time.
MID-STOP	Mid-Stop function will, when active, move the door from the down position to a predetermined Mid-stop position when the open button or Open/Close device is activated. Once at Mid-Stop, subsequent Open/close commands will close the door. To move the door to full open position, the open button must be pressed again.
TIMER TO CLOSE	Timer to Close is a function that, when active, will close the door after an adjustable time delay once the door has reached its fully open and mid-stop position. The timer to close function works only in T and TS modes.
TIMER TO CLOSE (from fully open position only)	Option used in conjunction with MID STOP function. When activated, Timer to Close is active from the fully open position only and not from the mid-stop position.
ADVANCE CLOSED TIME	This feature, when programmed, allows adjustment of the safety device disabling point and to determine the final stop point of the door once the "close limit switch" is activated. No "advance close limit switch" is needed with this feature.

7.3 PROGRAM SETTING

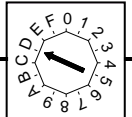
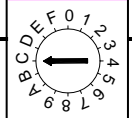
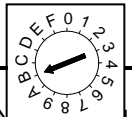
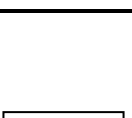
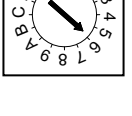
Door should be in fully closed position while setting of these following programs.

PROGRAM SETTING			
PROGRAMS	ACTIVATE	DEACTIVATE	SELECT SWITCH
RUN TIMER	<ul style="list-style-type: none"> Check if close limit switch is activated. Set select switch on D. Press "Open" button to add 10 sec to the total time needed to open the door. Set the select switch on (0,1 or 2) 	<ul style="list-style-type: none"> Set select switch on D. Press "Stop" button. 	
MID-STOP	<ul style="list-style-type: none"> Check the close limit is activated. Set select switch on "C" Press "Open" button then press "Stop" button on desired Mid-Stop position. 	<ul style="list-style-type: none"> Set select switch on "C" Press "Close" button. 	
TIMER TO CLOSE	<ul style="list-style-type: none"> Set select switch on "B" Press "Open" button to add 15 sec or "Close" button to add 1 sec each time (max. 4 minutes & 30 seconds) Set the select switch on T or TS mode 	<ul style="list-style-type: none"> Set select switch on "B" Press "Stop" button the timer to close is reset to 0 sec but still activated. To defeat the timer to close completely set the switch on desired position (0, 1, 2 or 3) 	
DEFEATE TIMER TO CLOSE (from floor level)	<ul style="list-style-type: none"> Press the "Stop" four times continuously on the push button station. (operator will operate as B2 mode) 	<ul style="list-style-type: none"> Press the "Close" button four times continuously on the push button station. (operator return to T or TS mode) 	
TIMER TO CLOSE (from fully open position only)	<ul style="list-style-type: none"> Set select switch on "6" First press the "Close" button and then the "Stop" 	<ul style="list-style-type: none"> Set select switch on "6" Press "Close" button. *Now the Timer to Close works from fully open and Mid-Stop position. 	
ADVANCE CLOSED TIME	<ul style="list-style-type: none"> Set the select switch on "7" Press "Open" to add 50 milliseconds up to 500 milliseconds max. Press "Close" to deduct 50 milliseconds each time till it reaches 0/sec. 	<ul style="list-style-type: none"> By pressing "Stop" the default time will be set to 100 milliseconds. * LED "INDICAT" comes ON only when time is increased or reduced. LED OFF when open or close button is pressed indicates "Advance Close Time" is reached Maxi or Mini. (pressing "Stop" LED ON = 100 milliseconds) 	
<p>The "close limit switch" should be readjusted when the "advance closed time" is programmed or deactivated</p>			

7.4 MODE SETTING

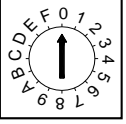
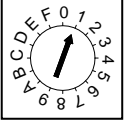
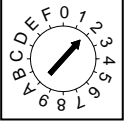
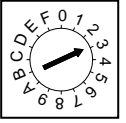
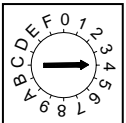
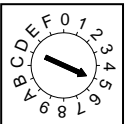
Wiring Type	Wiring Type & Functions	Select Switch
C2 (factory preset)	SET SELECT SWITCH ON 0 Momentary contact to open and stop, constant pressure to close with 3 buttons station. Activation of safety devices will reverse the door during closing. Auxiliary devices function as an Open control and to reverse door during closing.	
B2	Set the select switch on 1. Momentary contact to Open/Close and Stop with 3 buttons station. Activation of safety devices will reverse the door during closing. Auxiliary devices function as Open/Close control and reverse the door during closing.	
D1	Set the select switch on 2. Constant pressure to Open and constant pressure to Close. Activation of safety devices will stop the door during closing.	
E2	Set the select switch on 3 Momentary contact to open and constant pressure to Close. Release of Close button activates the door upwards. Activation of safety devices will reverse door motion to fully open position.	
T	Set the select switch on 4. Momentary contact to Open / Close and Stop. Timer to Close if programmed, safety devices reverse upon but will disable Timer to Close. Timer to close will also be disabled if there is a power outage, a chain hoist is engaged or the stop is pressed before elapsed time. The timer resumes its normal operation, once the close cycle is completed.	
TS	Set the select switch on 5. Momentary contact to Open / Close and Stop. Timer to Close if programmed, safety devices reverse upon activation and will refresh Timer to Close. Timer to close also gets refreshed, if there is a power outage, a chain hoist is engaged or a stop button is pressed before elapsed time.	

IMPORTANT NOTES:

- STOP JUMPER**

- While testing the operator or adjusting the cams using the O/C/S buttons available on the Electronic Control Board, a jumper should be placed between the #8 & #9. Once the tests or adjustments completed the jumper should removed before connecting the wall 3-push buttons station. Failure to remove the stop jumper, **the STOP BUTTON WILL NOT RESPOND.**
- A stop jumper should be installed between #8 & #9 when using a Key switch, a single button Radio control or a 2-buttons station (Open/Close). **IN THESE CONDITIONS NO STOP COMMAND IS AVAILABLE TO STOP THE DOOR DURING THE TRAVELLING.**

**WARNING**

MOTORIZED DOORS CAN CAUSE SEVERE INJURY OR DEATH. MANARAS STRONGLY RECOMMENDS THE USE OF ENTRAPMENT PROTECTION SYSTEMS, ESPECIALLY IN THE CASES OF MOMENTARY CONTACT TO CLOSE (B2 WIRING) AND TIMER TO CLOSE (T & TS).

7.5 CONNECTION OF A REVERSING EDGE DEVICE

IMPORTANT NOTE: If the door is controlled by any device other than a constant pressure push-button station, a reversing edge must be connected.



WARNING

Connect reversing device appropriate to installation.

Connection and installation of a reversing edge device is provided with the edge (also refer to page 18). Any such device that uses a normally open contact may be connected to terminals **3 and 5** on the low voltage terminal block. When the door comes in contact with an object during downward travel, the circuit will cause the motor to reverse the door to the fully open position. In addition, there is a cut-off limit switch (*advance close limit switch*) that will de-activate the reversing edge during the last few inches of the door's downward travel.

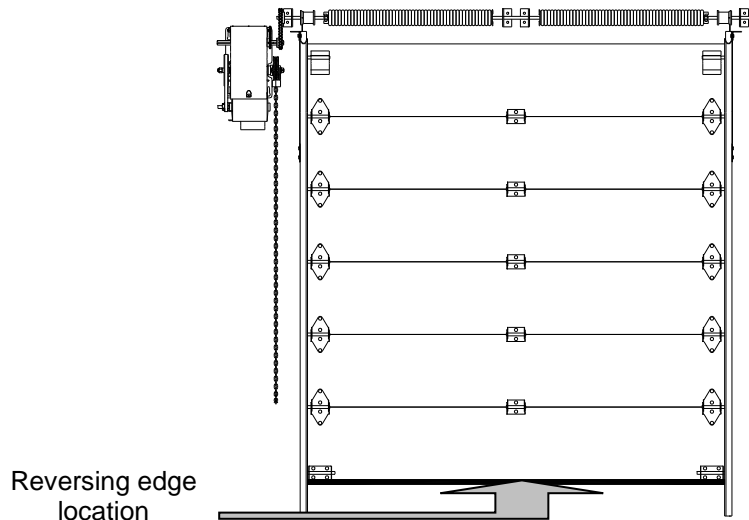

Figure 16 Reversing Edge

7.6 DOOR LOCK SENSOR & FRICTION CLUTCH

Please read carefully prior to installing this operator

All operators supplied with an electronic control board are equipped with the “DOOR LOCK SENSOR” feature.

The DOOR LOCK SENSOR prevents any damage to the door when the door lock hasn't been removed prior to electronic operation. It eliminates the need of expensive external interlock wiring.

This feature can only be used on operators equipped with a FRICTION CLUTCH.

When the lock stops the door, the clutch slips and in less than 1 second, the door will reverse a fraction of a second to release the lock.



WARNING

IN ORDER NOT TO DAMAGE THE DOOR WHEN THE LOCK IS ON, THE FRICTION CLUTCH HAS TO BE ADJUSTED PROPERLY ACCORDING TO THE INSTRUCTIONS PROVIDED ON PAGE 10

7.7 LIMIT SWITCHES



WARNING
TO AVOID THE DANGER OF POSSIBLE DAMAGE TO THE DOOR AND OPERATOR, TRAVELLING CAMS MUST BE ADJUSTED TO THEIR APPROXIMATE POSITIONS BEFORE MANUALLY OPERATING THE DOOR OR BEFORE APPLYING POWER TO THE OPERATOR.

Only 2 limit switches are used in operators built with an Electronic Control Board. One for the "Open" side and one for the "Close" side. No advanced Open or Closed limit switches is used. The microprocessor with the built-in logic replaces the advanced Open and Closed limit switches.

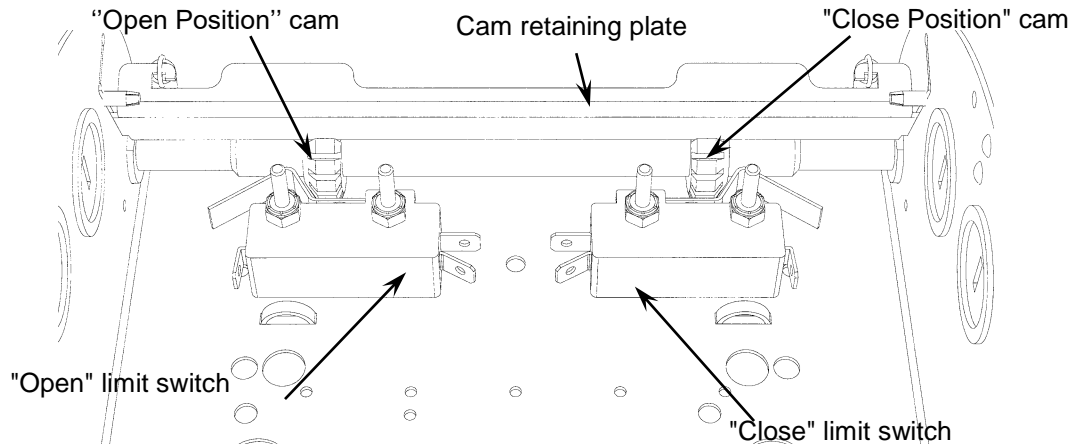

Figure 17 Limit switches

7.8 DESCRIPTION LIMIT SWITCHES

- The "Open" limit switch is the end of travel in the open position. Adjust the cam so that the door stops in the open position at the desired location.
- The "Close" limit switch is the end in the close position. Adjust the cam so that the door stops in the closed position at the desired position.

7.9 TROUBLE SHOOTING AN OPERATOR WITH ECB

Troubleshooting an operator with an ECB is easier since the LEDs provided on the circuit board help to bring a better diagnostic while finding faults.

Easy fix	Check the followings that may prevent the operator from starting before coming to any conclusion
Check light status on the ECB	Before starting any intervention, check the LEDs status and refer to the page 19 for a proper diagnostic.
Check the operating modes	Review the operating modes: B2, C2, D1, T or TS
Check the programming	A wrong programming on Timer to Close or Mid Stop will stop the door to an improper position.
Check the presence of stop jumper	If the 3 test buttons are being used without the stop jumper between #8 & #9, the operator will not respond to the 3 buttons command

TROUBLE SHOOTING GUIDE

SYMPTOM	PROBABLE CAUSE	SUGGESTED ACTION
Door will not respond to « open » or « close » push buttons	Check if STOP Led: if OFF.	
	Check if hoist is not engaged.	Disengage the hoist. (JP4 on 2-3 for trolley & sliding operators)
	Defective “stop” push button.	Replace.
	Check wiring from push button to operator	Replace if needed.
	Loose connection in one of the push buttons.	Verify, tighten or replace
	If STOP Led is ON.	
Defective “open” or “close” push button.	Replace.	
Door will not respond to “open” command, but will respond to “close” command	Check the “open” Led: if OFF	
	Replace the board	
	If “open” Led is ON	
	Defective “open” push button	Replace.
Defective “open” limit switch.	Replace.	
Loose wire on “open” push button, “open” limit switch.	Verify, tighten or replace.	
Door won’t respond to “close” command, but will respond to “open” command	Check the “close” Led: if OFF	
	Replace the board	
	If “close” Led is ON	
	Defective “close” push button.	Replace.
	Defective “close” limit switch.	Replace.
Loose wire on close push-button, close limit switch.	Verify, tighten or replace.	
Door move in wrong direction single or 3-phase operator	Motor rotation is reversed on board motor terminals.	Interchange #T13 and #T14 on the power board.
Stop button doesn’t stop the door	Two 3-push button stations connected in parallel.	Correct wiring (only stop buttons in series)
	Bad stop button.	Check and replace.
Sensing edge does not reverse door	Pneumatic hose broken.	Check and adjust.
	Bad air switch.	Check and adjust.
	Bad wiring.	Check and correct wiring.
When door closes it reverses to fully open after it hits the floor	The advanced close time is not proper adjusted.	Check and adjust.
	The close limit switch is not being engaged by traveling cam.	The close limit switch needs to be adjusted properly at the end of travel.
	An “open” command is given.	Check “open” push button or any opening device for short-circuit.
Motor hums, starts when spun (1 ph)	Capacitor defective.	Replace.
Motor relays buzz for a few seconds when door is stopped (1 ph)	Bleeder resistor faulty on capacitor.	Replace.
Motor fails to shut off at fully closed or opened position	Defective limit switch.	Operate limit switch manually while door is moving. If door does not stop, replace the switch.
	Limit cams are not adjusted.	Verify and adjust.
	Limit drive chain broken.	Replace.
	Loose sprocket on limit shaft.	Tighten setscrew.
	Limit shaft does not rotate.	Verify and replace accordingly.
Motor turns but door does not move	Sprocket key is missing.	Replace.
	Drive chain broken.	Replace.
	Limit shaft does not rotate.	Adjust clutch tension.
Limit switches do not hold their setting	Loose drive or limit chain allows chain to jump sprocket teeth.	Adjust chain to proper tension.
	Limit cam retainer not engaging slots in limit cams.	Be sure retainer is in slots of both cams.
	Limit cams are binding on shaft threads, which allow them to jump position on retainer.	Lubricate shaft threads. Limit cams should turn freely.
	Limit shaft have a light.	Verify and adjust.

7.10 Single phase ECB wiring diagram

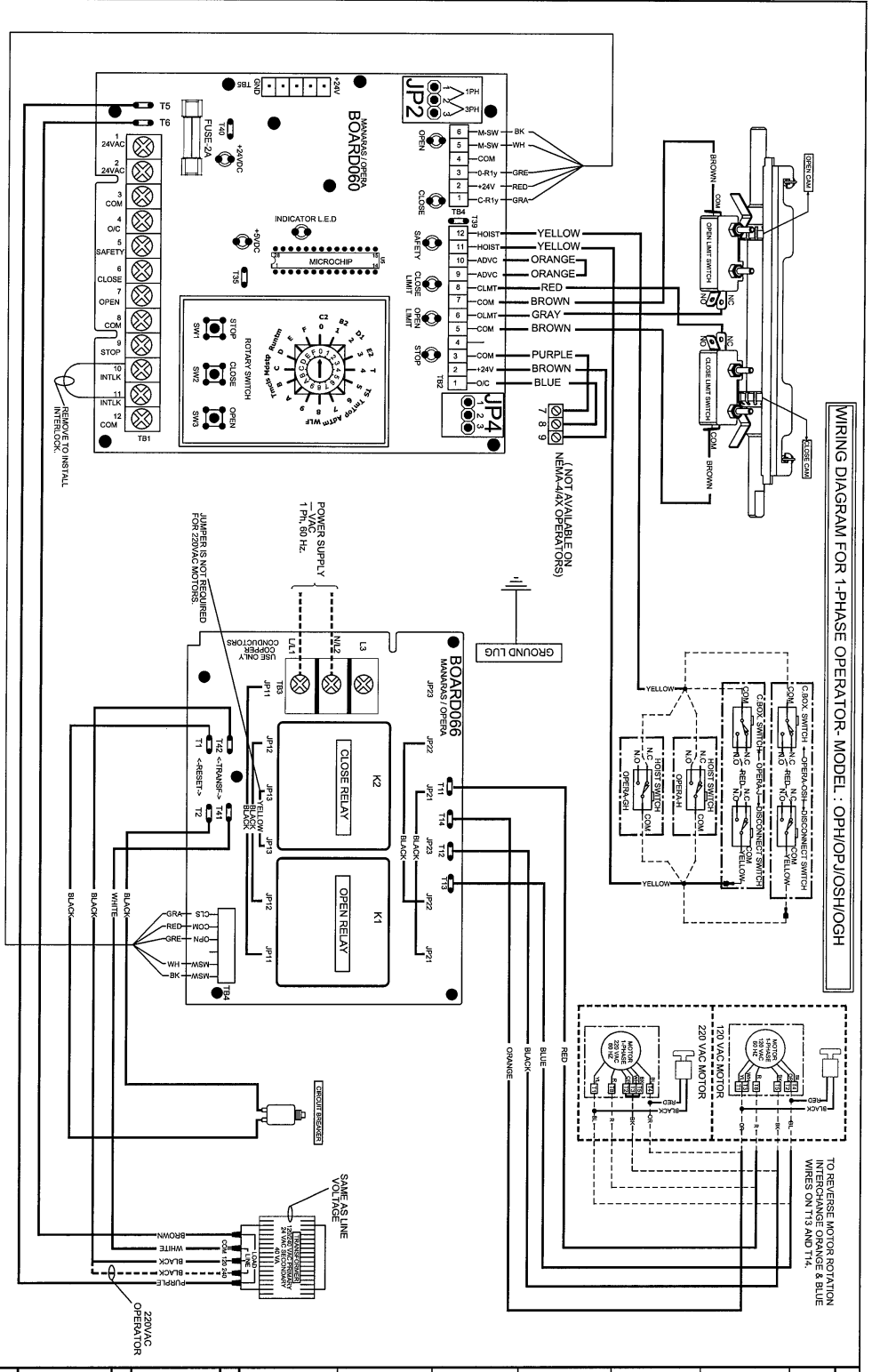

WIRING DIAGRAM FOR 1-PHASE OPERATOR MODEL: OPHOP/JOSH/HOCH

TO REVERSE MOTOR ROTATION INTERCHANGE ORANGE & BLUE WIRES ON T13 AND T14.

ROTARY SWITCH SETTINGS

WIRING TYPES	PROGRAM SETTINGS
0 C2	6 MID-STOP TIMER TO CLOSE
1 B2	7 ADV. CLOSE TIME
2 D1	8 WARNING LIGHT TIMER
3 E2	B TIMER TO CLOSE
4 T	C MID-STOP
5 TS	D RUN TIMER

ON BOARD JUMPER SETTINGS

JP2	JP4
1, 2, 3	1, 2, 3
1.2	1.2, 2.3

WARNING LIGHT/RECEIVER MODULE

CONNECTION FOR WARNING LIGHT AND RECEIVER MODULE (CONSULT FACTORY)

NOTE: FOR ROTARY SWITCH SETTINGS AND PROGRAMMING PROCEDURES, REFER TO INSTRUCTION MANUAL.

EXTERNAL WIRING

LINE POWER	EXTERNAL INTERLOCK	SAFETY REVERSE	OPEN/CLOSE COMMAND	SINGLE PUSH-BUTTON STATION	TWO PUSH-BUTTON STATION	RADIO RECEIVER	RADIO CONTROL TERMINAL STRIP
L/L1 N/L2 POWER SUPPLY -VAC, 60 Hz	24 VAC POWER 1 2	FACTORY INSTALLED JUMPER REMOVE IS USED	CONTACT FOR OPEN/CLOSE DEVICE	CONTACT FOR OPEN/CLOSE DEVICE	NOTE: PLACE A JUMPER BETWEEN TERMINALS 8 AND 9. IF STOP BUTTON IS NOT USED.	P.B. SW1 P.B. SW2	POWER PURPLE CONTACT BLUE GROUND BROWN
ATTENTION: USE 18AWG OR HIGHER FOR WIRING ALL EXTERNAL CONNECTIONS							

THE INFORMATION CONTAINED HEREIN IS PROPRIETARY TO MAMARAS/OPERA AND SHALL NOT BE REPRODUCED OR DISCLOSED OR USED FOR ANY DESIGN OR MANUFACTURE EXCEPT WHEN USER POSSESSES DIRECT WRITTEN AUTHORIZATION FROM MAMARAS/OPERA.

WIRING DIAGRAM, 120/208/220VAC, 1-PHASE

DRAWN BY: BP
DATE: 15 NOV 2008
DWG FILE: B00/OPR113.NI
REV. DATE: 15 JAN 2007

MAMARAS/OPERA 914-0720 QUEBEC INC.
136 OUELLETTE DRIVE
FOUR POINTES, QC H9R 1A8
TEL: 1-888-926-4200
FAX: 1-888-926-4900

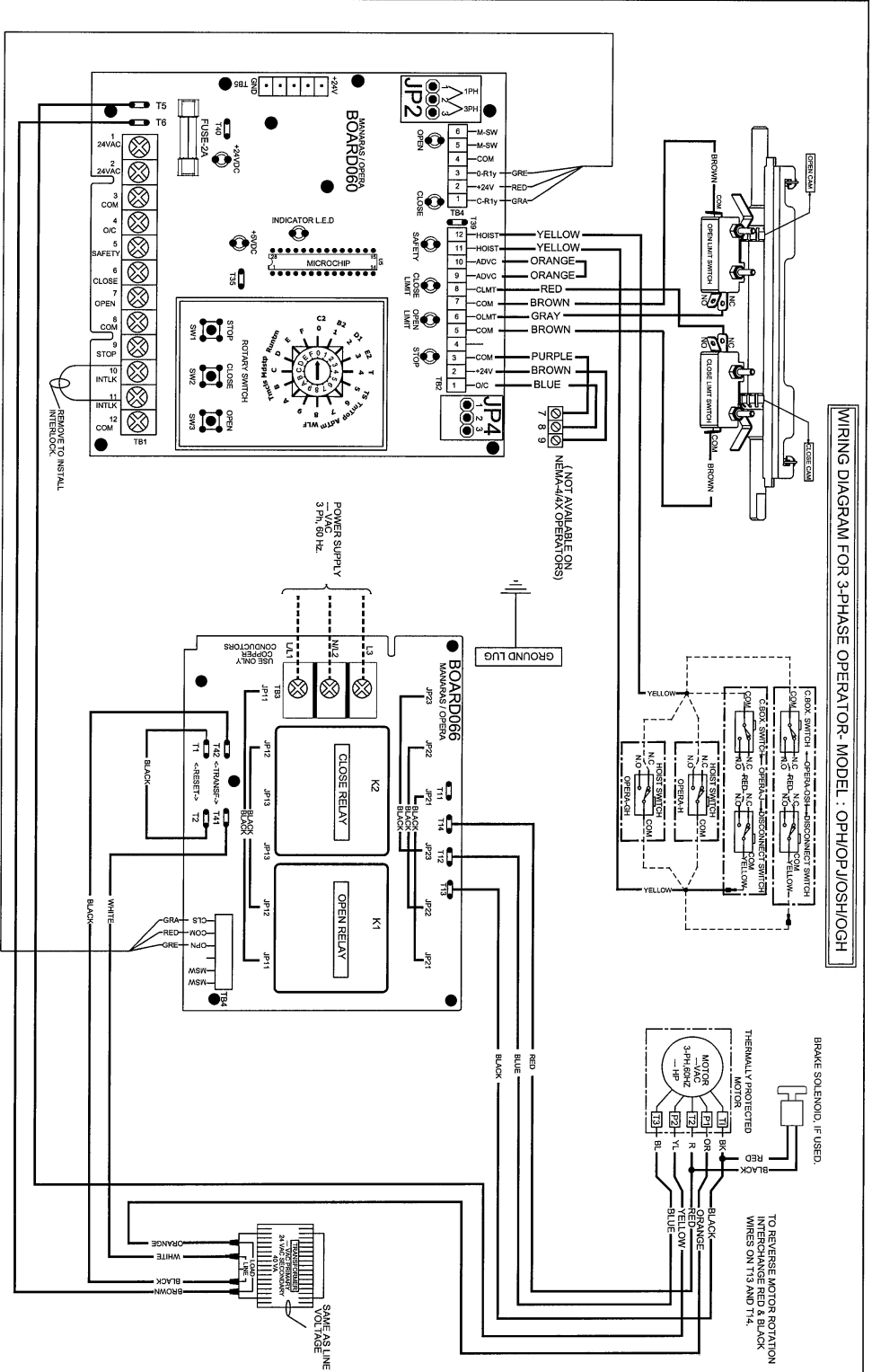

WIRING DIAGRAM FOR 3-PHASE OPERATOR- MODEL : OPHOPJOSHIOGH

EXTERNAL WIRING

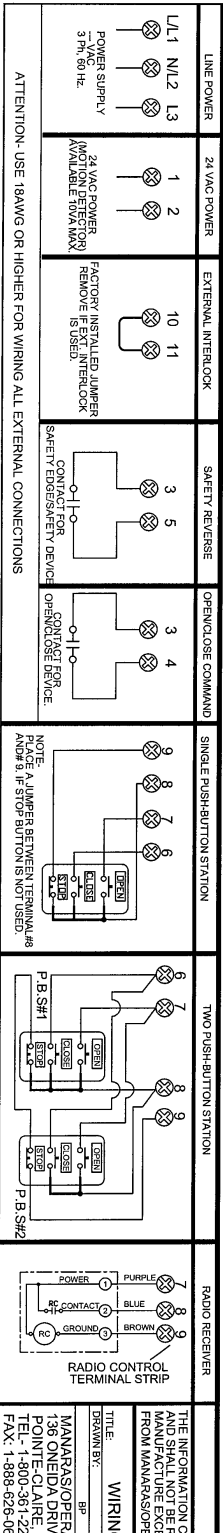

ROTARY SWITCH SETTINGS

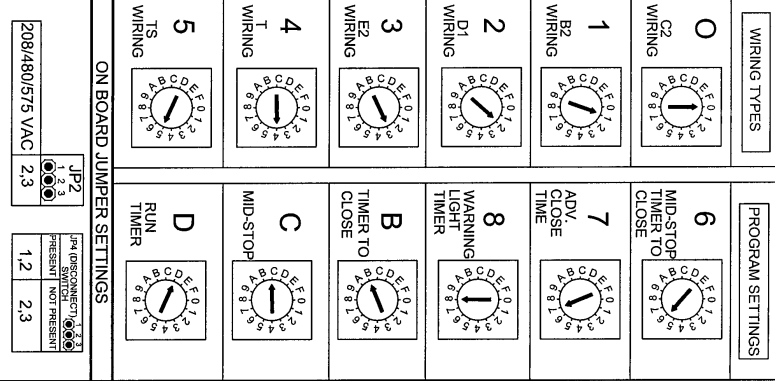

NOTE:
FOR ROTARY SWITCH SETTINGS AND PROGRAMMING PROCEDURES, REFER TO INSTRUCTION MANUAL.

THE INFORMATION CONTAINED HEREIN IS PROPRIETARY TO MANARSA/OPERA AND SHALL NOT BE REPRODUCED OR DISCLOSED OR USED FOR ANY DESIGN OR MANUFACTURE EXCEPT WHEN USER POSSESSES DIRECT WRITTEN AUTHORIZATION FROM MANARSA/OPERA.

WARNING LIGHT/RECEIVER MODULE
TBS CONNECTION FOR WARNING LIGHT AND RECEIVER MODULE (CONSULT FACTORY)

ON BOARD JUMPER SETTINGS

208/480/575 VAC 2,3

JP2 JP1 (DISCONNECT) 1,2,3

JP3 (PUSH SWITCH) 1,2,3

JP4 (PUSH SWITCH) 1,2,3

DATE: 15/NOV/2008
DRAWN BY: BRG/GRE33-AN1
REVIEW DATE: 15/JAN/2007

MANARSA/OPERA 9140-0720 QUEBEC INC.
136 OUELLET DRIVE
TAINVILLE, QUEBEC H9R 1A8
TEL: 1-888-625-6969
FAX: 1-888-625-6966

WIRING DIAGRAM, 208/480/575VAC, 3- PHASE

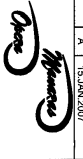

8. Specific section for operators supplied with

ECB

&

WARNING LIGHTS

(RED & GREEN)

8.1 Warning Light Sequence

Lights	Operating sequence
Red	The light is solid red when the door is closing and opening. Light turns OFF once the door reaches the fully open or fully closed position
Green	The green light is ON only when the door is fully open and stays ON during a preset time (programmed by the Timer to Close)
Red (flashing)	The red light starts flashing once the green light is OFF and when the door is about to close. This is to warn the users that the door will close shortly. It stops flashing once the door start closing.
Warning lights sequence is operational from Mid-Point position in same way as from fully open	

8.2 Programming warning lights sequence (door should be in the closed position)

NOTE: Warning lights is functional only with Timer to Close

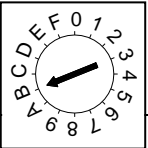
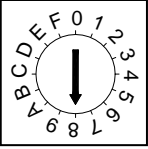
SETTING	ACTIVATE	DEACTIVATE	SELECT SWITCH
TIMER TO CLOSE	<ul style="list-style-type: none"> Set select switch on "B" Press "Open" button to add 15 sec or "Close" button to add 1 sec each time (max. 4 minutes & 30 seconds) Set the select switch on T or TS mode 	<ul style="list-style-type: none"> Set select switch on "B" Press "Stop" button the timer to close is reset to 0 sec but still is activated. To deactivate the timer to close completely set the switch on desired position (0, 1, 2 or 3) 	
RED LIGHTS (Flashing Time)	Default time setting 5 sec		
	<ul style="list-style-type: none"> Set select switch on "8" Press "Open" to add 1 sec each time to a maximum of 15 sec. Press "Close" to deduct 1 sec each time to a minimum of 0 sec. Press "Stop" to bring the flashing time to 5 sec by default 	<ul style="list-style-type: none"> Set select switch on "8" and press "Close" to bring the flashing time to 0 sec. Or set the select switch to desired position (0, 1, 2 or 3) 	

8.3 Connection of Red and Green warning lights

(If Warning Lights Module is sold separately)

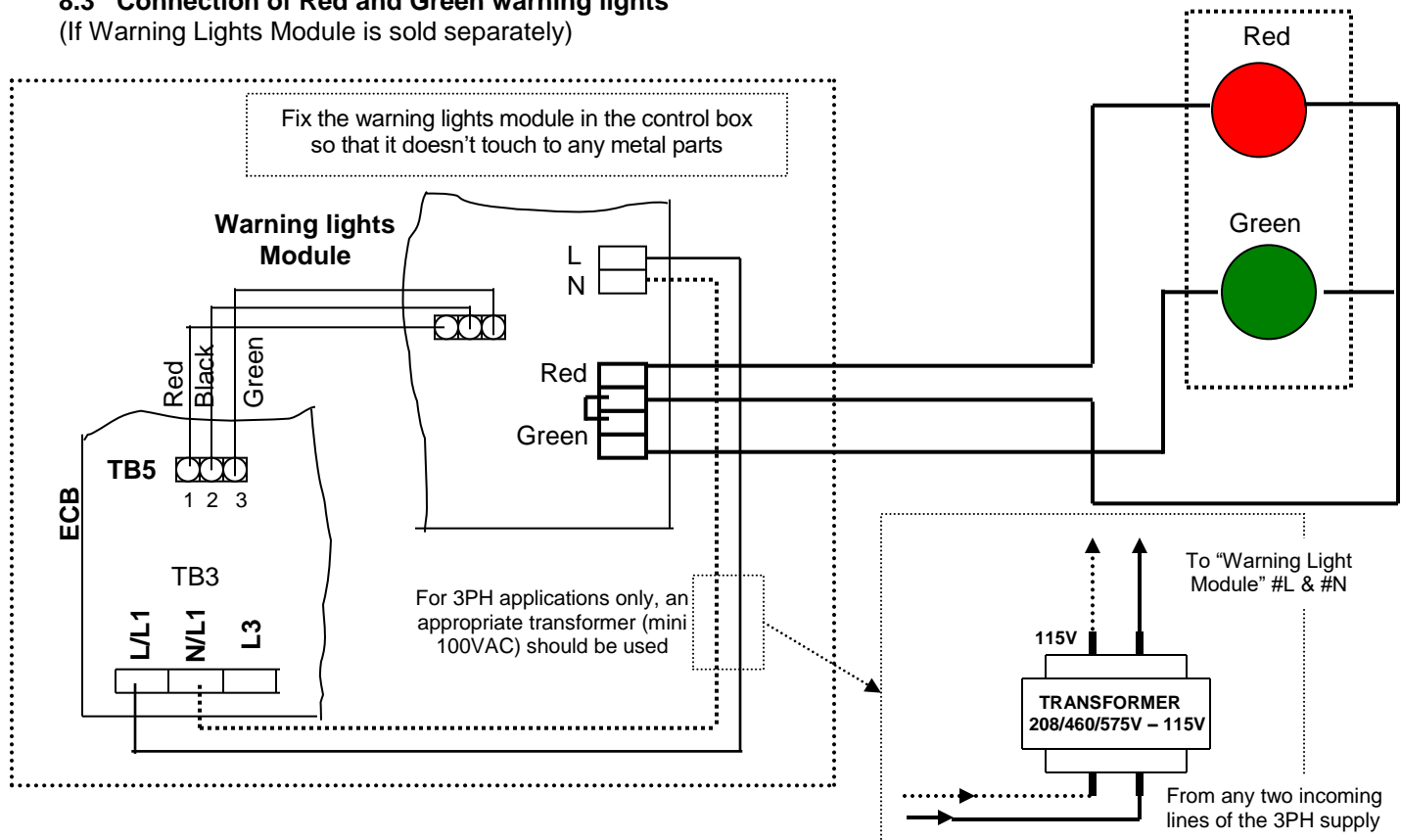

9. Specific section for operators supplied with

ELECTROMECHANICAL CIRCUIT

(Contactor Circuit)

- 9.1 WIRING OF AN Opera-H & J**
- 9.2 B2/C2 WIRING**
- 9.3 OPTIONAL CONTROL ACCESSORIES**
- 9.4 CONNECTION OF REVERSING EDGE**
- 9.6 LIMIT SWITCHES**
- 9.7 OPERATOR START-UP AND TESTING**
- 9.8 TROUBLESHOOTING GUIDE**

NOTE: Please refer to page 17 for hardwired operators.

9.1 WIRING OF THE OPERA OPERATOR

Do NOT connect any accessory controls until the limit switch adjustments have been completed and the operator is functioning properly.

Refer to the electrical diagrams on pages 40 and 41 and the accessory wiring diagrams on page 34 and 35.



WARNING

EXERCISE CAUTION WHEN OPERATING MACHINE. THE DRIVE CHAIN AND LIMIT CHAIN, WHEN EXPOSED AND TURNING, COULD CAUSE SEVERE INJURY.

NOTE: Wiring diagrams are glued on the inside the control box cover. If the diagram is faded or damaged, call the factory for a replacement. DO NOT INSTALL ANY WIRING OR ATTEMPT TO RUN THIS OPERATOR WITHOUT CONSULTING THE WIRING DIAGRAM.

Main Power Supply

Power to the operator is of the permanent connection type. Connect according to local electrical code. Ground the unit using the ground lug inside the control box.

IMPORTANT: Be aware of the dimension of the power supply cables pipe (BX for ex.) It must not limit the control box movement to access the mechanical reduction parts. It is recommended to add 7 or 8 inches.

For single phase operators, connect the power supply to terminals L (line) and N (neutral) on the main terminal strip.

For three phase operators, connect the power supply to terminals L1, L2 and L3 on the main terminal strip.

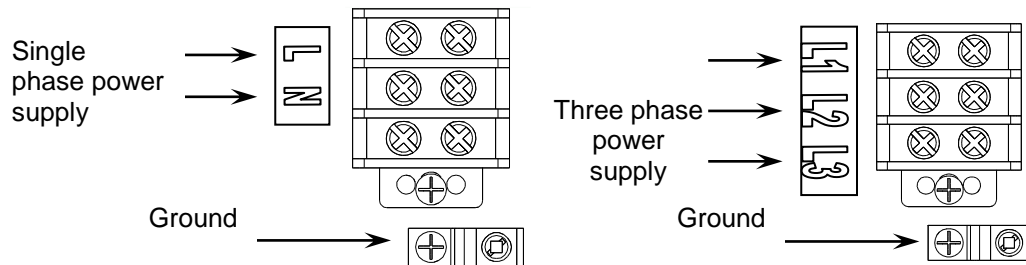

Figure 18 Power supply connection



WARNING

GROUND THE UNIT CORRECTLY USING THE COPPER GROUND LUG LOCATED INSIDE THE OPERATOR CONTROL BOX.

NOTE: All other connections on the terminal strip (1 to 9) are low voltage class II 24 VAC.

- External interlock between terminals 1 and 2. A jumper is factory installed between these two terminals. If an external interlock is used (such as interlocking between two doors), remove the jumper between 1 and 2 and wire the interlock between these two terminals.

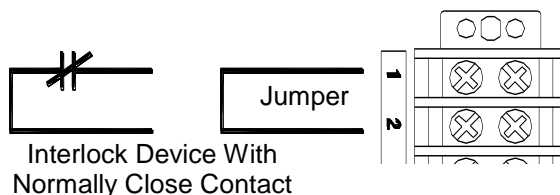

Figure 19 External interlock

2. A 3 button push-button station (open/close/stop) can be wired to terminals 2, 3, 4 and 5. Two push-button stations can be wired to these same terminals by following the wiring diagrams on pages 49 and 41.

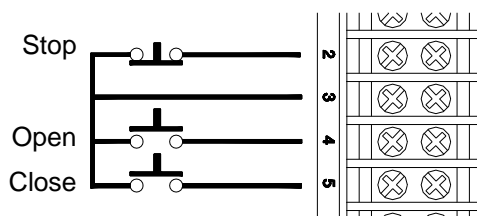

Figure 20 Three button push-button station

3. Three terminals are provided for the wiring of a radio-control receiver. Terminal #9 is Ground, #7 is 24 VAC (common) and #8 is the relay contact provided by the radio-control receiver to activate the door to open or close. Furthermore, terminals 7, 8 and 9 are doubly available on the terminal strip inside and on a separate small terminal strip located on the side of the unit. This terminal makes it convenient to wire-up a standard single button radio receiver on the side of the unit. When the transmitter is activated, the door will open to the fully open position. From the fully open position, the door will close. If transmitter is activated while closing, the door will reverse to the fully open position.

NOTE: It may be required to reverse connections to 7 and 9 for other types or radio receivers (Allstar, Linear, Pulsar ...).

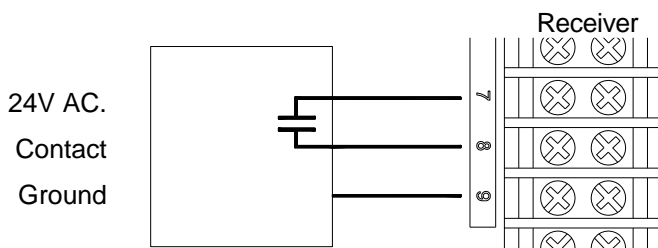

Figure 21 Radio-control

NOTE: (select B2)
Radio Control = B2 wiring
 Momentary contact to open, close and stop with a 3 buttons station.

4. A single button open/close door device can be wired to terminals 7 and 8 to behave in the same way as the radio control receiver.

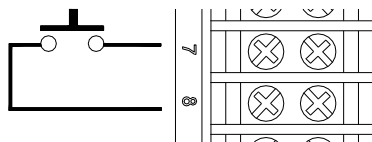

Figure 22 Single button device

NOTE: (select B2)
Open/Close = Radio Control
 Momentary contact to open and close with single button station.

NOTE: If several control devices are to be used, connect one and check for proper operation before connecting the next device.

5. A reversing edge can be wired up to terminals 3 and 6. These terminals can also be used for any other reversing devices such as loop detectors and photocells.

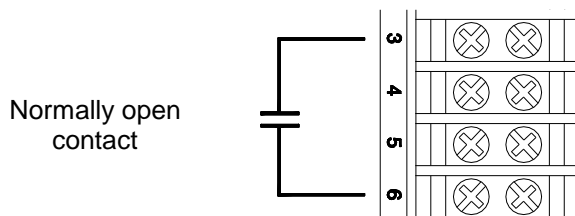
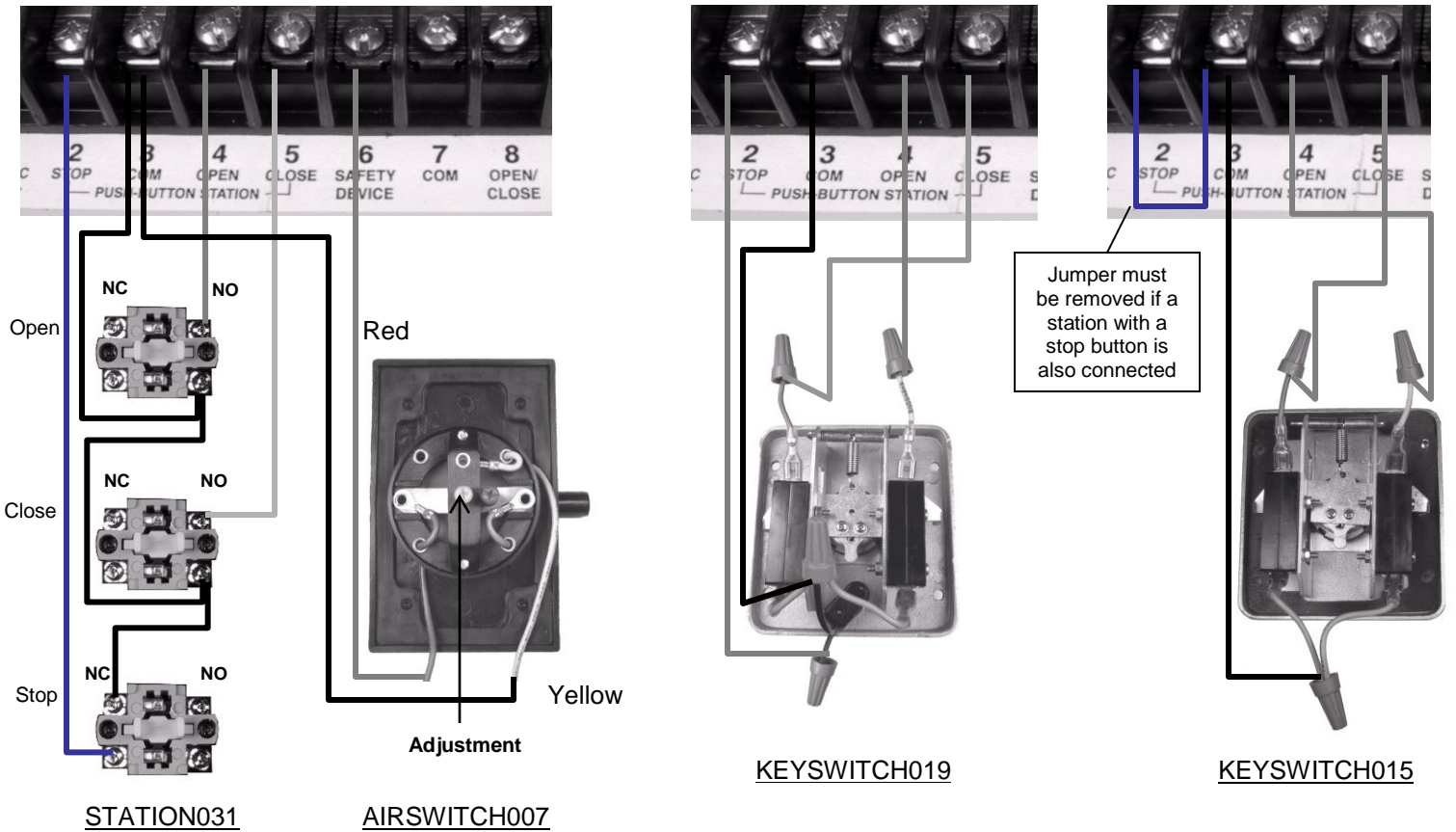
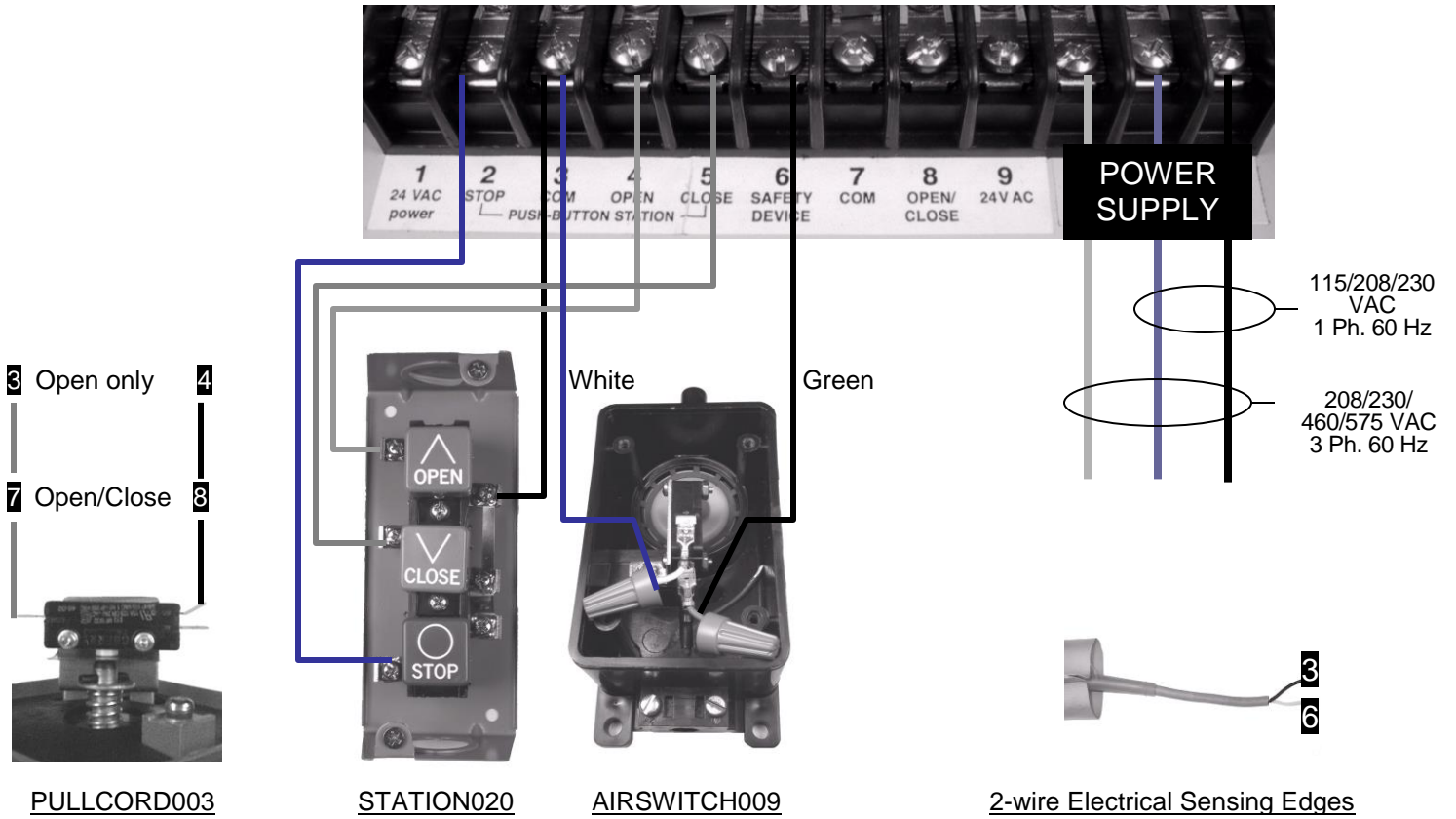

Figure 23 Reversing edge or other device

IMPORTANT: Upon completion of all wiring connections, readjust limits as mentioned in section 9.1 using "Open", "Close" and "Stop" buttons.

9.2 Accessory Wiring



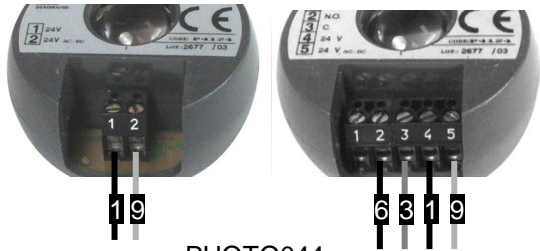

PHOTO044

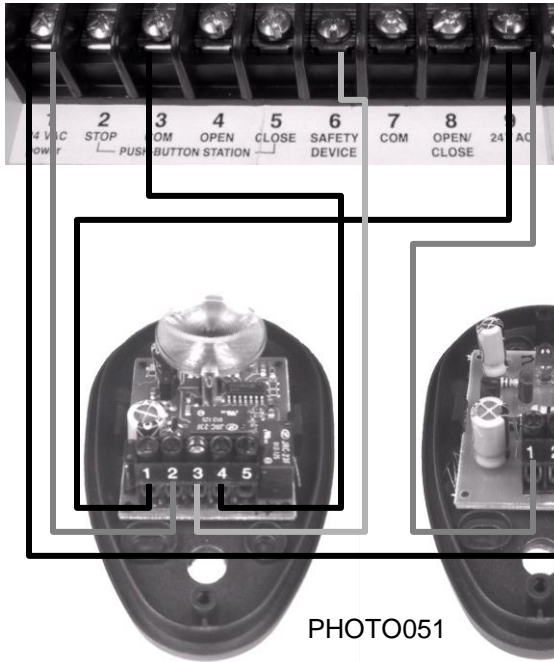
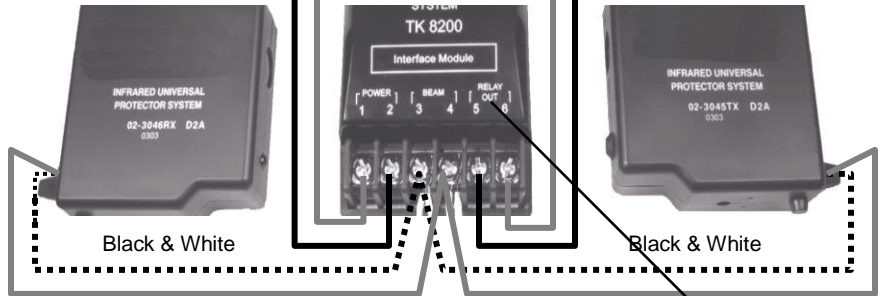
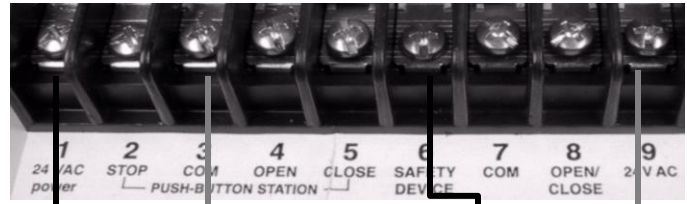

PHOTO051



White

PHOTO008

White

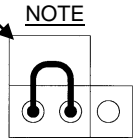

Interface Module Jumper (TK8200)

Always set the jumper located inside the Interface Module on N.O. (Normally Open)



PHOTO038

- Blue 1
- Brown 9
- Orange 3
- White 6

FOR MOMENTARY CONTACT TO CLOSE (B2 WIRING), PLEASE REFER TO INSTRUCTION BELOW

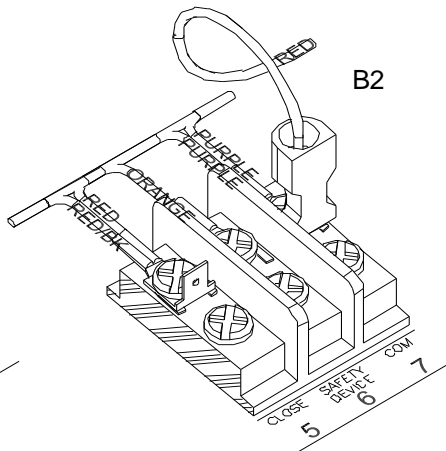
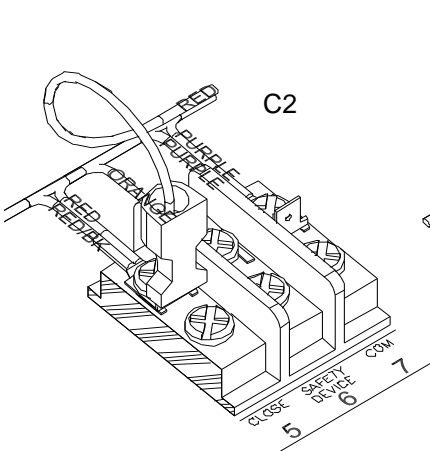

C2 wiring: momentary contact to open and stop, constant pressure to close with 3 push button station. Activation of safety device will reverse the door during closing. Auxiliary devices to function as an open/control and to reverse the door during closing.

C2 to B2
Move red wire from #5 to #7

B2 wiring: momentary contact to open, close and stop with 3 push button station. Activation of safety device will reverse the door during closing. Auxiliary devices to function as an open/close control and to reverse the door during closing.

B2 to C2
Move red wire from #7 to #5

! WARNING

Motorized doors can cause serious injuries or death. Manaras strongly recommends the use of entrapment protection systems, especially in the case of momentary contact to close such as with B2 wiring or timer to close.

! WARNING

- Wall control(s) must be located so that the door is within sight of the user.
- If momentary contact (B2 mode) is used, an external reversing device must be installed.

9.3 CONNECTION OF A REVERSING EDGE DEVICE

IMPORTANT NOTE: If the door is controlled by any device other than a constant pressure push-button station, a reversing edge must be connected.



WARNING

CONNECT REVERSING DEVICE APPROPRIATE TO INSTALLATION.

Connection and installation of a reversing edge device is provided with the edge (also refer to Figure 24). Any such device that uses a normally open contact may be connected to terminals **3 and 6** on the low voltage terminal block. When the door comes in contact with an object during downward travel, the circuit will cause the motor to reverse the door to the fully open position. In addition, there is a cut-off limit switch (*advanced close limit switch*) that will de-activate the reversing edge during the last few inches of the door's downward travel.

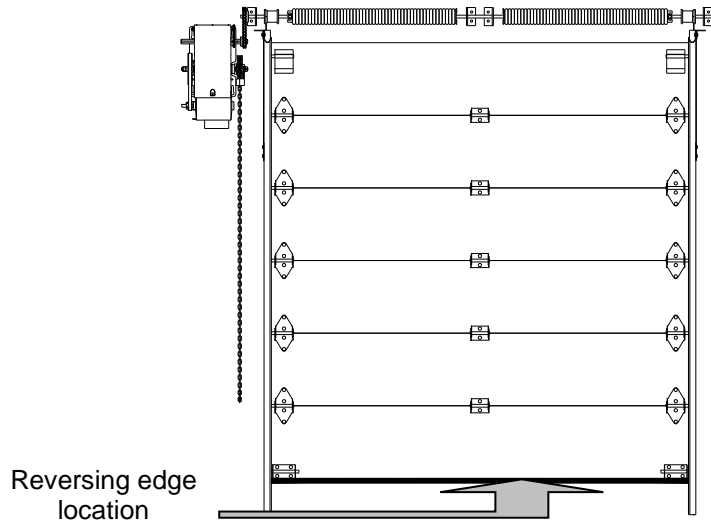

Figure 24 Reversing Edge

9.4 LIMIT SWITCHES



WARNING

TO AVOID THE DANGER OF POSSIBLE DAMAGE TO THE DOOR AND OPERATOR, TRAVELLING CAMS MUST BE ADJUSTED TO THEIR APPROXIMATE POSITIONS BEFORE MANUALLY OPERATING THE DOOR OR BEFORE APPLYING POWER TO THE OPERATOR.

There are 4 limit switches. Two are used as end of travel, one is for radio-control or one-button operation and one is for reversing devices. These switches are activated by the rotary cams travelling on a threaded shaft (Figure 25).

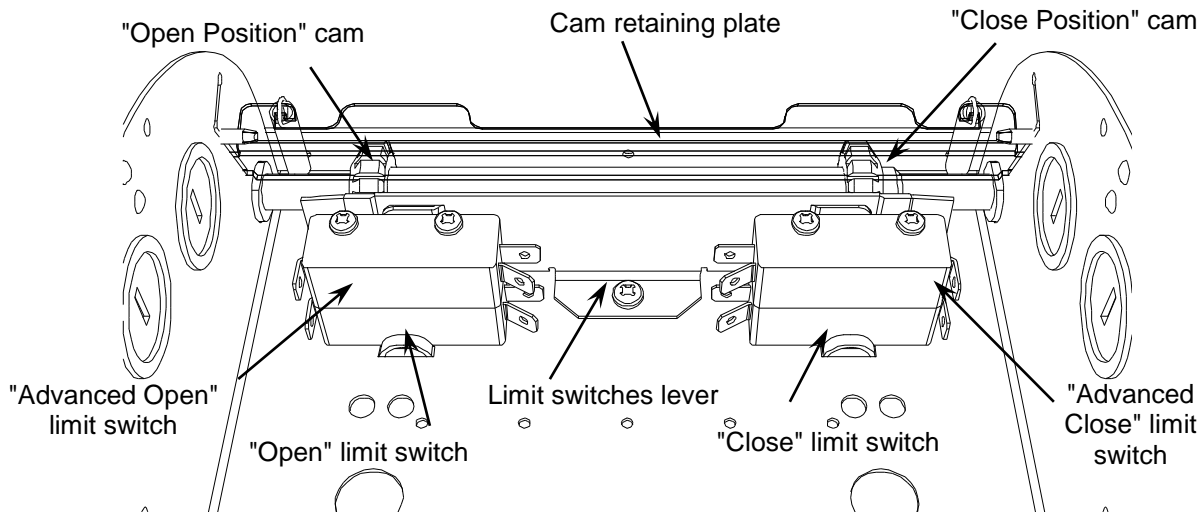

Figure 25 Limit switches

DESCRIPTION LIMIT SWITCHES

- The “Open” limit switch is the end of travel in the open position. Adjust the cam so that the door stops in the open position at the desired location.
- The “Advanced Open” limit switch is used for radio control (open/close) feature and to activate the timer to close the door if a timer is used
- The “Close” limit switch is the end in the close position. Adjust the cam so that the door stops in the closed position at the desired position.
- The “Advanced Closed” limit switch is used in the operation of the reversing edge or other reversing devices. This limit switch prevents a signal from a reversing edge or device to reverse the door when it is almost fully closed.

9.5 OPERATOR START-UP AND TESTING GUIDE



DANGER

WHILE PERFORMING THE TESTS LISTED BELOW, IT'S VERY IMPORTANT TO HAVE A POWER SHUT-OFF DEVICE NEAR BY OR SOMEONE TO TURN THE POWER OFF WHEN NEEDED.

This guide is a procedure you can follow to test every feature of your door operator.

If a 3 button push-button station is wired to the operator, disconnect it and then place a normally closed contact between terminals 2 and 3 to simulate a "Stop" push-button (use a spare limit switch or any such device). Interrupting the power between these terminals will stop the operator.

Using a small wire jumper, momentarily jump (short-circuit) the following terminals:

- A. Momentarily jump terminals 3 and 4.
The door will open instantly. Allow it open completely.
- B. Momentarily jump terminals 3 and 5.
The door will close instantly. Allow it close completely.
- C. Momentarily jump terminals 7 and 8.
The door will open instantly. Allow it to open completely.
- D. Momentarily jump terminals 7 and 8.
The door will close instantly. While closing, go to step E.
- E. Momentarily jump terminals 7 and 8 again.
The door will reverse to open. Allow it to open completely.
- F. Momentarily jump terminals 7 and 8.
The door will close. While closing, go to step G.
- G. Momentarily jump terminals 3 and 6.
The door will reverse to open. Allow it to open completely.
- H. Momentarily jump terminals 7 and 8 again.
The door will close. Allow it to close completely.
- I. Momentarily jump terminals 3 and 6.
The door should remain still.

This procedure can be repeated using the radio-control terminal strip located on the outside of the control box by using terminals "24VAC" and "CONTACT" instead of terminals 7 and 8.

9.6 TROUBLE-SHOOTING GUIDE

All operators are thoroughly tested and adjusted before shipping. In most cases, it is after installation and hook-up to external devices that a problem will arise.

If after connecting external devices to the operator, you encounter problems, the trouble often lies in the external devices or in the wiring leading to the external devices. Verify all external wiring making certain that there are no wires pinched anywhere shorting to ground and that there are no voltages being sent into the control circuit. The operator functions ONLY with dry contacts: all voltages necessary for proper functioning are generated by the operator transformer.

The following trouble-shooting guide (TABLE 2) will help you identify the source of the problem given a particular symptom.

TABLE 2 TROUBLE-SHOOTING GUIDE

SYMPTOM	PROBABLE CAUSE	SUGGESTED ACTION
Door will not respond to "open" or "close" push-buttons.	Machine is in disconnect position (Opera-J).	Make free the disconnect chain from the Opera-J chain keeper.
	Chain hoist is engaged which activated the disconnect switch (Opera-H)	Pull on chain slightly in each direction in order to disengage the chain hoist and return the operator to electrical operation. Check switch otherwise.
	Motor has overworked and the overload thermal protection has tripped.	Reset the overload protection: press reset button located on the side of the unit for a single phase operator. For a three phase operator, the thermal switch is inside the motor, let motor cool and restart operator. Is the door unbalanced?
	Circuit breaker tripped (if used).	Reset circuit breaker.
	Fuse is blown.	Replace fuse. If control circuit fuse keeps blowing: Disconnect all external devices. Leave power terminals connected. Run the operator artificially by using jumpers and shorting out the appropriate terminals as indicated in the Start-Up and Testing Guide. Then reconnect the various external devices one by one until you find the one causing the short to ground. OR: If you have an ohm-meter, use it to check all incoming wires for continuity to ground. The meter should read infinity in all instances. If there is conduction between any control circuit wire and ground, this indicates a leak to ground and this is why the control circuit fuse blows when power is applied. In some cases, the trouble is intermittent: i.e. the fuse only blows at certain times. This problem is more difficult to detect, but again: disconnect all wires going to external devices, and run the operator: if the fuse does not blow, this indicates that the trouble resides outside the operator.
	Transformer defective.	Replace.
	Defective "stop" push-button.	Replace.
	Loose connection in one of the push-buttons.	Verify, tighten or replace.
	Defective "open" or "close" push-button.	Replace.
Door will not respond to "open" command, but will respond to "close" command.	Defective "open" push-button.	Replace.
	"Open" cam has been overdriven.	Reinsert cam back onto the threaded shaft and readjust <i>Open</i> position.
	Defective "open" limit switch.	Replace
	Loose wire on "open" push-button, "open" limit switch or coil of open contactor.	Verify, tighten or replace.
Door will not respond to "close" command, but will respond to "open" command.	Defective "close" push-button.	Replace.
	"Close" cam has been overdriven.	Reinsert cam back onto the threaded shaft and readjust <i>Close</i> position.
	Defective "close" limit switch .	Adjust.
	Loose wire on close push-button, close limit switch or coil of close contactor.	Verify, tighten or replace.
Door moves in wrong direction.	Incorrect phasing on a three phase operator.	Interchange any two power leads.
	Wrongly connected on a single phase operator.	Interchange Black and White motor leads on contactor.
Door closes and operator does not shut-off at the end of closing travel.	"close" contactor is defective.	Verify and replace.
	"close" limit switch defective	Verify and replace.
Door opens and operator does not shut-off at the end of opening travel.	"open" contactor is defective.	Verify and replace.
	"open" limit switch is defective.	Verify and replace.

SYMPTOM	PROBABLE CAUSE	SUGGESTED ACTION
Sensing edge does not reverse door.	Pneumatic hose broken, electrical wiring not connected.	Contact a qualified installer.
Reversing devices will open the door when the door is closed.	The <i>advanced close</i> limit switch is defective.	Replace.
	The <i>advanced close</i> limit switch is not being engaged by travelling cam.	The <i>advanced close</i> limit switch needs to be adjusted just slightly ahead of the end of travel <i>Close</i> limit switch.
When door closes it reverses to fully open after it hits the floor.	The <i>advanced close</i> limit switch is defective.	Replace.
	The <i>advanced close</i> limit switch is not being engaged by travelling cam.	The <i>advanced close</i> limit switch needs to be adjusted just slightly ahead of the end of travel <i>Close</i> limit switch.
	A "Close" command is being given.	Check "Close" push-button or any closing device for short-circuit.
Radio-control does not function or hesitates for 10 seconds before working.	It is normal for a radio receiver to take up to 10 seconds to "warm-up" before being fully operational. Therefore, when applying power for the first time, the radio-control will take 10 seconds before becoming fully operational.	Check protocol code pins of the transmitter and receiver: they must be the same. Press on the transmitter and listen to the receiver: you should hear a faint click. The transmitter battery may be dead or your receiver may need servicing. To test for radio-control function, short out momentarily terminals 7 and 8 on the terminal strip. Operator should function normally. Have the radio-control verified: the mini-relay inside the receiver may be defective.
Motor hums, starts when spun.	Capacitor defective. (single phase only)	Replace
Motor fails to shut off at fully closed or opened positions.	Defective limit switch.	Operate limit switch manually while door is moving. If door does not stop, replace switch.
	Limit cams are not adjusted.	Verify and adjust.
	Limit drive chain broken.	Replace.
	Loose sprocket on limit shaft.	Tighten set screw.
	Limit shaft does not rotate.	Verify and replace accordingly.
Motor turns but door does not move.	Sprocket key is missing.	Replace.
	Drive chain is broken.	Replace.
	One of the reduction chains is broken	Replace.
	Clutch is slipping.	Adjust clutch tension.
Motor hums or does not run.	Door locked or jammed.	Verify manual operation of door.
	Dead phase (three phase supply).	Check power supply, fuses on each phase.
Limit switches do not hold their setting.	Loose drive or limit chain allows chain to jump sprocket teeth.	Adjust chain to proper tension
	Limit cam retainer not engaging slots in limit cams.	Be sure retainer is in slots of BOTH cams.
	Limit cams are binding on shaft threads which allows them to jump position on retainer.	Lubricate shaft threads. Limit cams should turn freely.
Radio-control opens and reverses the door, but when the door is fully opened, will close the door a little and bounce back to the open position again. Door cannot be closed except by the "close" push-button.	The <i>Advanced Open</i> limit switch is insufficiently advanced from the full <i>Open</i> limit switch. The contact of the radio-control receiver is maintained for 1.5 seconds when a command is issued by the radio transmitter. Therefore, when the door is fully opened, and a pulse is sent from the transmitter, the receiver maintains the contact closed for 1.5 seconds. If the door has closed and the <i>Advanced Open</i> limit switch has returned to its normal state, the reversing relay will be activated, and the door bounces back to the open position.	Adjust the <i>Advanced Open</i> limit switch by bending the limit switch lever punch away from the travelling cam and more towards the <i>Open</i> limit switch.

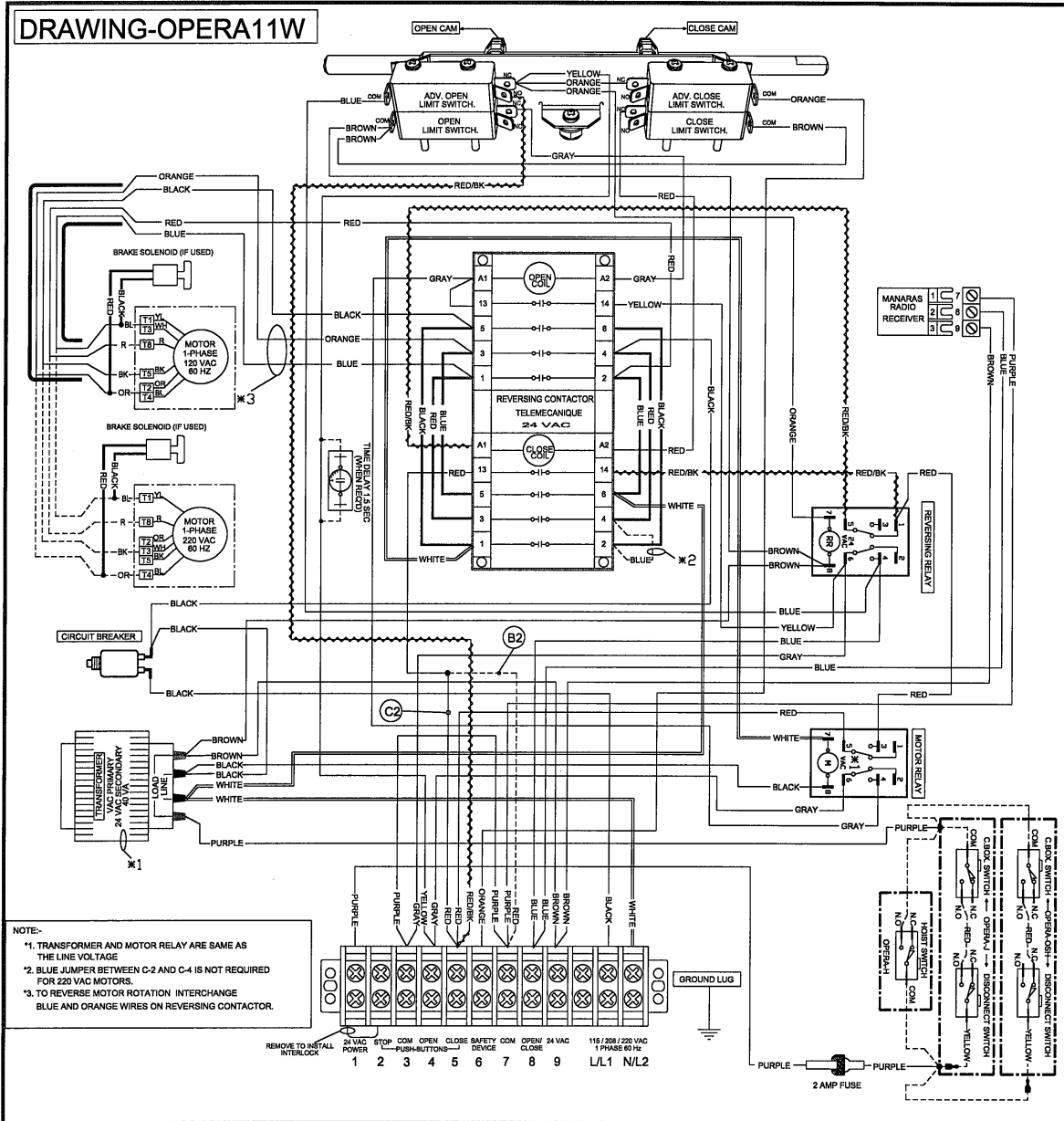

NOTE:-

- *1. TRANSFORMER AND MOTOR RELAY ARE SAME AS THE LINE VOLTAGE
- *2. BLUE JUMPER BETWEEN C-2 AND C-4 IS NOT REQUIRED FOR 220 VAC MOTORS.
- *3. TO REVERSE MOTOR ROTATION INTERCHANGE BLUE AND ORANGE WIRES ON REVERSING CONTACTOR.

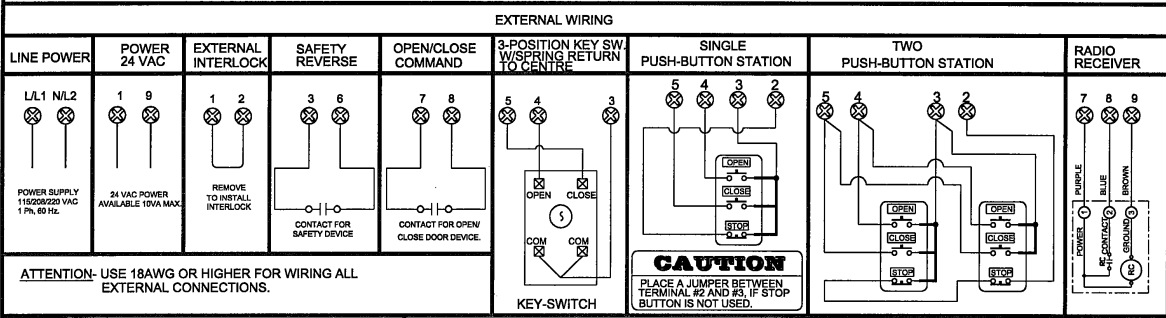

ATTENTION: USE 18AWG OR HIGHER FOR WIRING ALL EXTERNAL CONNECTIONS.

1 NOTE-C2/ B2

1A C2 ⇌ B2 REMOVE THE RED WIRE WITH RAPID CONNECTOR FROM TERMINAL #5, AND TRANSFER IT TO TERMINAL #7.

1B B2 ⇌ C2 REMOVE THE RED WIRE WITH RAPID CONNECTOR FROM TERMINAL #7, AND TRANSFER IT TO TERMINAL #5.

WARNING: MOTORISED DOORS CAN CAUSE SERIOUS INJURIES OR DEATH. MANARAS STRONGLY RECOMMENDS THE USE OF ENTRAPMENT PROTECTION SYSTEMS, ESPECIALLY IN THE CASES OF MOMENTARY CONTACT TO CLOSE AS IN B2 WIRING OR TIMER TO CLOSE.

ON SITE MODIFICATIONS

2 CONSTANT PRESSURE OPEN

- REMOVE THE GRAY WIRE FROM TERMINAL #3 AND PLACE IT ON TERMINAL #4

3 WIRING FOR INSTANT STOP (ON SAFETY EDGE OR DEVICE)

- REMOVE THE YELLOW WIRE FROM ADV. OPEN LIMIT SWITCH, AND CAP IT.
- REMOVE THE BLUE WIRE FROM PIN #4 OF REVERSING RELAY (RR) AND CAP IT.

4 ADDING A TIME DELAY ON REVERSE

ADV. OPEN L.S. ORANGE ORANGE BLUE YELLOW

YELLOW 1.5 SEC. T.D. MODULE

- REMOVE THE YELLOW WIRE FROM ADV. OPEN LIMIT SWITCH, CONNECT THIS WIRE TO ONE END OF TIME-DELAY.
- FROM OTHER END OF THE TIME-DELAY, CONNECT BACK TO ADV. OPEN LIMIT SWITCH.

5 CONSTANT PRESSURE OPEN AND CLOSE - D1

PERFORM THE MODIFICATION EXPLAINED IN THE NOTES, 1B 2 AND 3

6 ANY OTHER OPTIONS

FOR ANY OTHER OPTIONS LIKE, TIMER TO CLOSE, MID-STOP WIRING, LONG DISTANCE MODULE OR ANY OTHER SPECIAL LOGIC SEQUENCE PLEASE CONSULT MANARAS AT 1-800-361-2260 (CAN) 1-866-77-6732 (USA)

TITLE: WIRING DIAGRAM- 115/208/220 VAC 1-PHASE

DRAWN BY: BP **DATE:** 27.MAR.2001 **CAD FILE:** OPERA11W **REV. DATE:** 27.OCT.2004

MANARAS SOMFY ULC. 136 ONEIDA DRIVE, POINTE-CLAIRE, QC H9R 1A8

Manarás Somfy International

THE INFORMATION CONTAINED HEREIN IS PROPRIETARY TO MANARAS SOMFY ULC, AND SHALL NOT BE REPRODUCED OR DISCLOSED OR USED FOR ANY DESIGN OR MANUFACTURE EXCEPT WHEN USER POSSESSES DIRECT WRITTEN AUTHORIZATION FROM MANARAS SOMFY ULC.

DRAWING-OPERA31JW

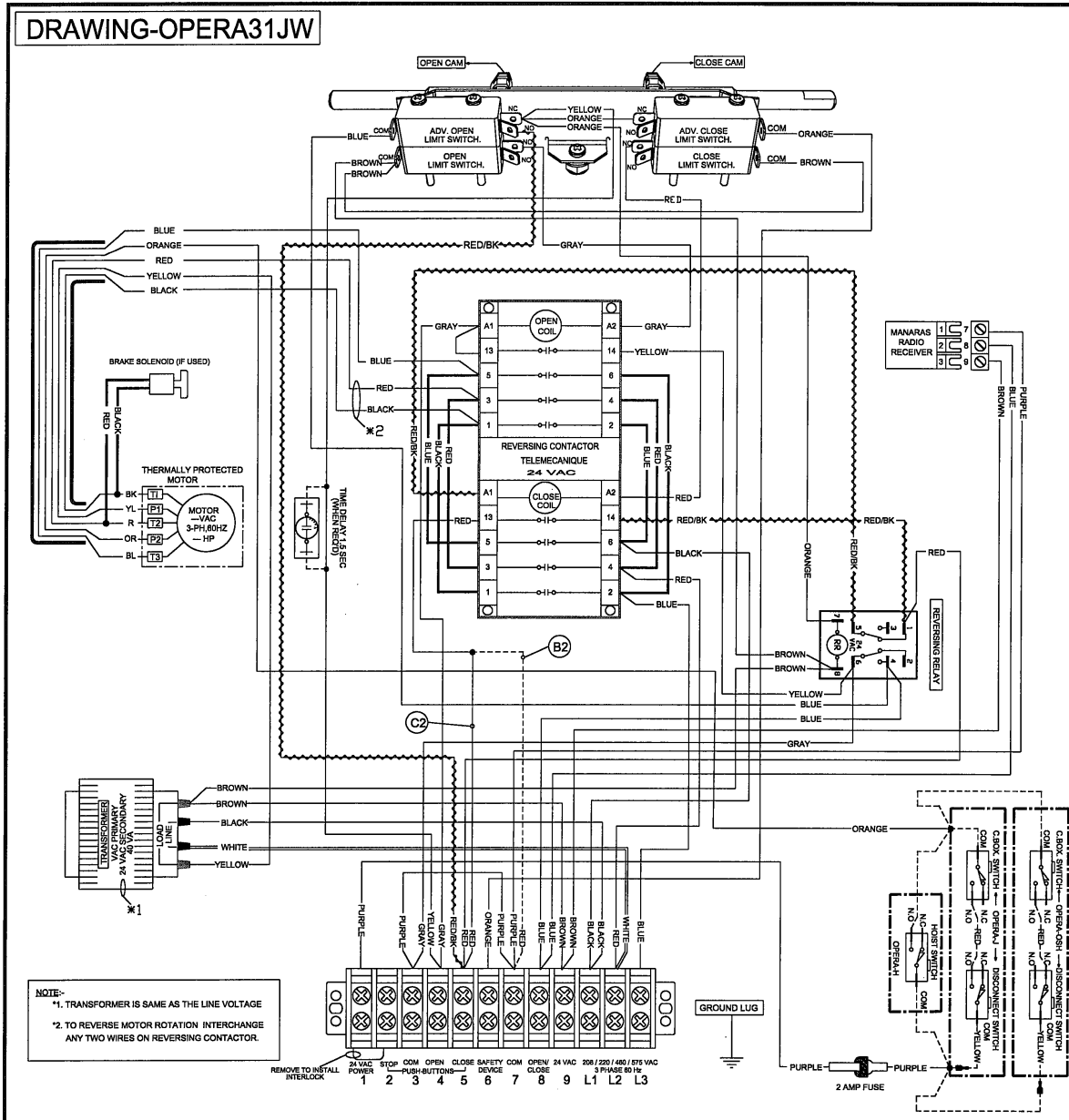

NOTE:-
 *1. TRANSFORMER IS SAME AS THE LINE VOLTAGE
 *2. TO REVERSE MOTOR ROTATION INTERCHANGE ANY TWO WIRES ON REVERSING CONTACTOR.

EXTERNAL WIRING

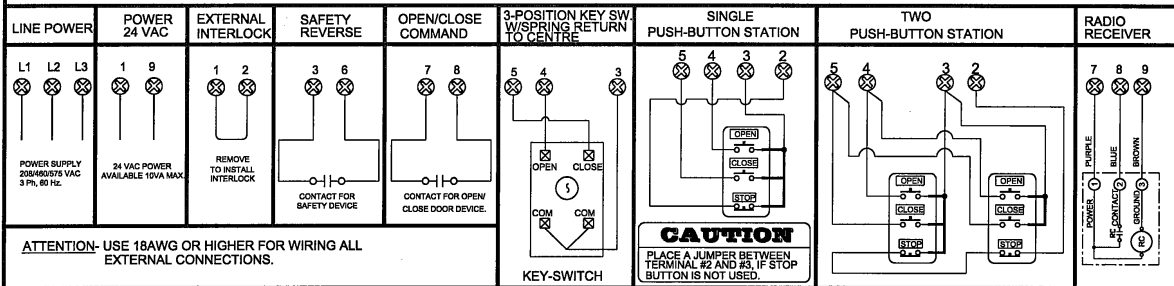

ATTENTION- USE 18AWG OR HIGHER FOR WIRING ALL EXTERNAL CONNECTIONS.

<p>1 NOTE-C2/B2</p>	ON SITE MODIFICATIONS	
<p>1A C2 ⇌ B2 REMOVE THE RED WIRE WITH RAPID CONNECTOR FROM TERMINAL #5, AND TRANSFER IT TO TERMINAL #7.</p>	<p>2 CONSTANT PRESSURE OPEN 1. REMOVE THE GRAY WIRE FROM TERMINAL #3 AND PLACE IT ON TERMINAL #4</p>	<p>4 ADDING A TIME DELAY ON REVERSE ADV. OPEN L.S. ORANGE ORANGE BLUE YELLOW 1. REMOVE THE YELLOW WIRE FROM ADV. OPEN LIMIT SWITCH; CONNECT THIS WIRE TO ONE END OF TIME-DELAY. 2. FROM OTHER END OF THE TIME-DELAY, CONNECT BACK TO ADV. OPEN LIMIT SWITCH.</p>
<p>1B B2 ⇌ C2 REMOVE THE RED WIRE WITH RAPID CONNECTOR FROM TERMINAL #7, AND TRANSFER IT TO TERMINAL #5.</p>	<p>3 WIRING FOR INSTANT STOP (ON SAFETY EDGE OR DEVICE) 1. REMOVE THE YELLOW WIRE FROM ADV. OPEN LIMIT SWITCH, AND CAP IT. 2. REMOVE THE BLUE WIRE FROM PIN #4 OF REVERSING RELAY(RR) AND CAP IT.</p>	<p>5 CONSTANT PRESSURE OPEN AND CLOSE - D1 PERFORM THE MODIFICATION EXPLAINED IN THE NOTES, 1B 2 AND 3</p>
<p>WARNING: MOTORISED DOORS CAN CAUSE SERIOUS INJURIES OR DEATH. MANARAS STRONGLY RECOMMENDS THE USE OF ENTRAPMENT PROTECTION SYSTEMS, ESPECIALLY IN THE CASES OF MOMENTARY CONTACT TO CLOSE AS IN B2 WIRING OR TIMER TO CLOSE.</p>	<p>6 ANY OTHER OPTIONS FOR ANY OTHER OPTIONS LIKE, TIMER TO CLOSE, MID-STOP WIRING, LONG DISTANCE MODULE OR ANY OTHER SPECIAL LOGIC SEQUENCE PLEASE CONSULT MANARAS AT 1-800-361-2260 (CAN) 1-866-77-8732 (USA)</p>	
<p>TITLE: WIRING DIAGRAM- 208/460/575 VAC 3-PHASE DRAWN BY: BP DATE: 06.FEB.2001 CAD FILE: OPERA31JW REV DATE: 27.OCT.2004</p>		
<p>MANARAS SOMFY U.L.C. 138 ONEIDA DRIVE POINTE-CLAIRE, QC H8R 1A8</p>		

THE INFORMATION CONTAINED HEREIN IS PROPRIETARY TO MANARAS SOMFY U.L.C. AND SHALL NOT BE REPRODUCED OR DISCLOSED OR USED FOR ANY DESIGN OR MANUFACTURE EXCEPT WHEN USER POSSESSES DIRECT WRITTEN AUTHORIZATION FROM MANARAS SOMFY U.L.C.

WARRANTY

Manaras warrants its operators to be free from defects in material and workmanship under normal and proper use for a period of two years from date of invoice. Mechanical, electrical and electronic accessories are warranted for one year from date of invoice. Wearing parts such as clutch pads, v-belts, and brake bands are excluded from warranty.

Manaras' only obligation shall be to repair or replace defective equipment which does not conform to the warranty. Manaras shall not be liable for any injury, loss or damage, direct or consequential, arising out of the inability to use the equipment. Before using, Buyer and/or the ultimate User shall determine the suitability of the product for its intended use, and User assumes all risks and liability in connection therewith. The foregoing may not be changed except by an Agreement signed by an authorized representative of Manaras.

The articles that are replaced pursuant to the terms of this warranty shall be retained by Manaras, and the User is responsible for any freight costs relating to repair or replacement.

The foregoing warranty is exclusive and in lieu of all other warranties of quality, whether written, oral or implied (including any other warranty of merchantability or fitness for purpose).

The following are exclusions from warranty:

- If usage, product modification, adaptation or installation are not in accordance with our installation and operating instructions.
- If the product has been opened, dismantled or returned with clear evidence of abuse or other damage.
- If our written specifications are not properly applied by the Buyer when selecting the equipment.
- If our written instructions for installation and wiring of the electrical connections have not been followed.
- If our equipment has been used to perform functions other than the functions it was designed to handle.
- If Manaras equipment is used with electrical accessories (switches, relays, etc.) that have not been previously approved in writing by the Manaras Engineering Department.
- If electrical accessories and other components have been used in disregard of the basic wiring diagram for which they were designed.

All costs related to installation and reinstallation of the Manaras equipment covered by this warranty are not the responsibility of Manaras. Manaras will not be responsible for any consequential damages during the following installation procedures. If the Buyer resells any Manaras products to another Buyer or End-user, it shall include all of the terms and provisions of this warranty in such resale. Manaras' responsibility to any such Third Party shall be no greater than Manaras' responsibility under the warranty to the original Buyer.

Returns

No returns will be accepted without prior written authorization by Manaras. All returns must be accompanied by a Return Authorization Number issued by Manaras, and all unauthorized returns will be refused. The return shipment is to be freight prepaid by the Buyer, and under no circumstances shall the Buyer deduct the value of the returned merchandise from any remittance due. A restocking fee of 15% of Manaras sale price will be charged.

NOTES

Commercial Door OPERAtor

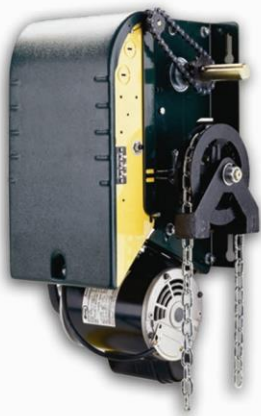

Manaras is extending their well-known OPERA brand name across its entire line of commercial OPERAtor products. Over the years, the OPERA brand name has become synonymous with innovation and reliability. The high quality products you have come to expect from us will now be backed by the OPERA brand name. We will continue to meet your individual needs while striving to balance quality, performance and experience with a personalized touch. When you think Manaras just think OPERA.

Call us for more information:
1-800-361-2260



"Easy to install. Easy to use. Year after year."

www.manaras.com

BOOK151 REV 1 - 2007/02/20